

Filter element

2-stage filter elements for lubricating oil filtration

Resistant to differential pressure up to 30 bar, nominal size 110 to 220 l/min

1. Brief description

2-Stage filter element for lubricating systems

The Filtration Group 2-stage filter element with the unique Premium Select element structure, with integrated reliable bypass valves and the sturdy safety insert is used as for gear oil filtration in wind turbine plants. These filter elements are used in the oil filter modules Pi 831x and the low-pressure filters Pi 260.

- Filter elements with two filtration stages for the filtration of lubricating in wind turbine gearboxes
- Unique, multilayer Filtration Group Premium Select (PS) folding star-shape filter design made of chemically and thermally resistant materials
- Filter performance that fits like a glove: A force-fit fixing fleece material presses the folding star-shape tight to the supporting body and fixes the folds in place in such a way as to prevent block formation. At the same time, the fixing fleece takes over a pre-filter function
- Progressive structure: The degree of fineness of the glass fibre material decreases from the inside to the outside, combining the advantages of a depth filter with those of a large effective filtering surface. The result: greater dirt pick-up capacity even at lower pressure loss in conjunction with a defined discharging rate (multipass test in compliance with ISO 16889)
- Supporting fibre on both sides made of high-quality stainless steel ensures the high rigidity of the folding star-shape
- Chemical resistance is guaranteed by the use of high-grade stainless steel wire mesh
- Supporting body and end plates are made of materials free of chromium VI
- Suitable for universal use for hydraulic and lubricating fluids, fuels, aqueous media and synthetic fluids
- Low initial differential pressure
- Version for Filtration Group filter housing, as alternative elements in the dimensions of other manufacturers and in customer-specific designs
- High differential pressure stability and dirt pick-up capacity of the elements
- Global sales



2. Quality assurance

Filtration Group filters and filter elements are manufactured and/or tested in compliance with the following international standards:

Norm	Titel
DIN ISO 2941	Hydraulic fluid power; filter elements; verification of collapse/burst resistance
DIN ISO 2942	Hydraulic fluid power; filter elements; verification of fabrication integrity
DIN ISO 2943	Hydraulic fluid power; filter elements; verification of material compatibility with fluids
DIN ISO 3723	Hydraulic fluid power; filter elements; method for end load test
DIN ISO 3724	Hydraulic fluid power; filter elements; determination of resistance to flow fatigue
ISO 3968	Hydraulic fluid power-filters-evaluation of pressure drop versus flow characteristics
ISO 10771.1	Fatigue pressure testing of metal containing envelopes in hydraulic fluid applications
ISO 16889	Hydraulic fluid power filters-multipass method for evaluation filtration performance of a filter element

3. Funktional description

The filter element is the central component in which the filtration process takes place.

The 2-stage filter elements used for lubricating oil filtration in wind turbines are a combination of depth filter (1st filter stage – glass fibre) and surface filter (2nd filter stage – wire mesh).

The direction of flow through the 2-stage filter element is from the outside to the inside. The first filter stage (1), the multilayer star-pleated depth filter, is responsible for the prescribed purity class being achieved. Inside the first filter stage, the protection filter (2) is installed in such a way that only filtered oil is allowed to flow into the gearbox.

There are 2 operating modes, normal mode and bypass mode

Normal mode:

The bypass valves (3) in the upper end plate are closed so that the unfiltered oil flows through the 1st filter stage (1), the depth filter.

Then the pre-filtered oil flows the 2nd filter stage (2), the surface filter.

Bypass mode:

With a lubrication system cold start, the viscosity of the lubricating oil (ISO VG 320) can be so high that the pressure built up at the filter element is high enough to open the bypass valves (3). This means that part of the unfiltered oil flows past the first filter stage (1) and gets into the inside of the 2-stage filter element unfiltered and flows through the second filter stage (2). This guarantees that the wind turbine gearbox is always supplied with filtered oil.

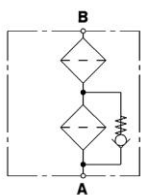
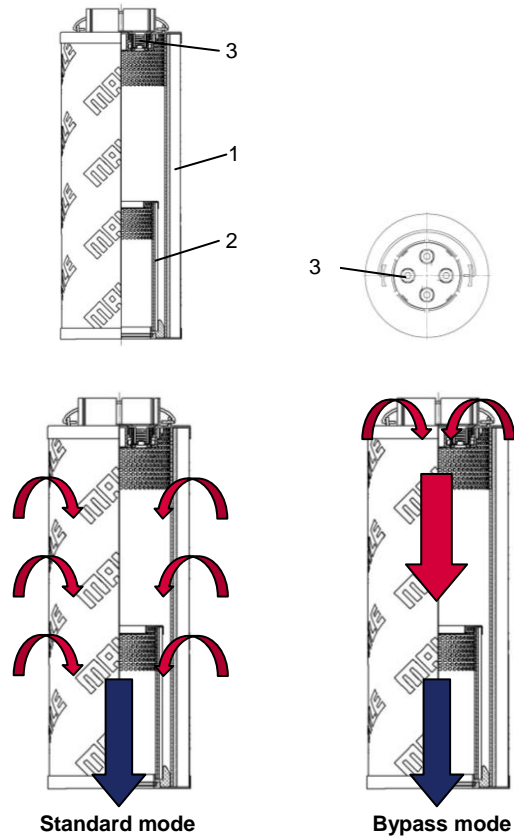

4. Filter media

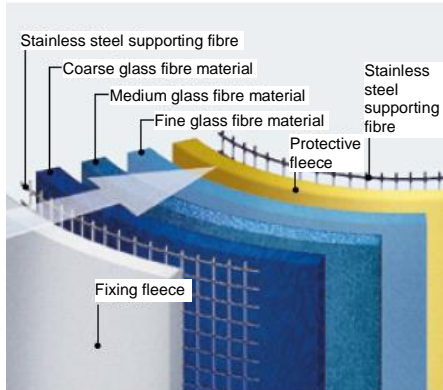

Structure of a PS folding star-shape

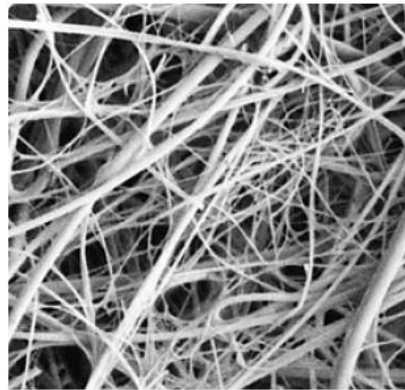

Micro-fibre glass

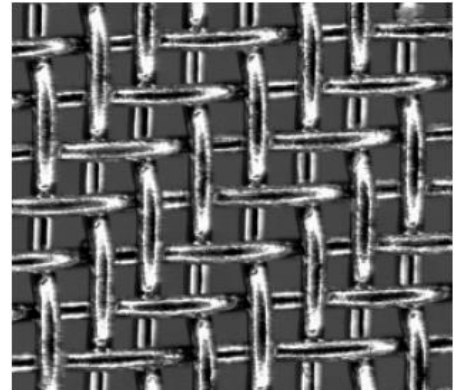

Wire mesh

4.1 Filter media PS

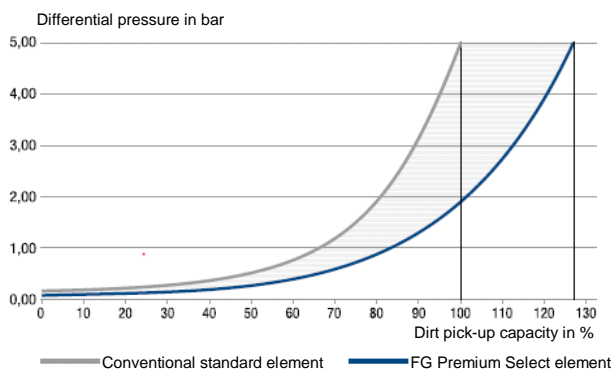

Permanently more capacity plus longer service life: innovative Premium Select element with 30% increase in dirt pick-up capacity, lower differential pressure and optimised differential pressure curve – for reduced energy consumption.

There is a complete range of filter elements available for use in wind power applications. Our Filtration Group Premium Select elements reduce solid soiling to the prescribed soiling class and maintain the properties of the lubricating fluid over a long period.

Our Filtration Group Premium Select elements are tested to all the usual hydraulic standards. Because we want results we can objectively prove to customers. For this reason, we only monitor our products against globally recognised standards such as ISO 16889. Here, our filters achieve outstanding values for dirt pick-up capacity, beta-value stability and retaining rate.

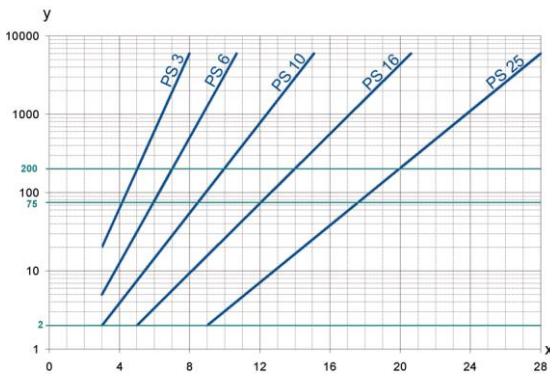

y = beta value
x = particle size [μm]

determined from multipass measurements (ISO 16889)
Calibration in accordance with ISO 11171 (NIST)

In a hydraulic or lubricating system, the filters have the task of keeping the soiling level of the fluid to the required level by filtering out particulate matter and keeping this level constant over a long operating period. In industrial hydraulics, it is usual to use codes for the numbers of particles in accordance with ISO 4406 to mark solid impurities. The purity classes which can be achieved with PS filter elements are listed below. These values reflect our long years of experience in designing hydraulic filters and are to be viewed as reference values.

Purity classes	
Filter material	Purity classes in accordance with ISO 4406 (1999), > 4 $\mu\text{m(c)}$ / > 6 $\mu\text{m (c)}$ / >14 $\mu\text{m (c)}$
PS 3	14/12/09
PS 6	16/13/10
PS 10	17/15/11
PS 16	20/17/12
PS 25	23/19/13

measured in accordance with ISO 16889 (multipass test)

PS elements with max. Δp 10 bar

PS	3 $\beta_{5(C)}$	≥ 200
PS	6 $\beta_{7(C)}$	≥ 200
PS	10 $\beta_{10(C)}$	≥ 200
PS	25 $\beta_{20(C)}$	≥ 200

up to 10 bar differential pressure

4.2 Filter media Drg

The filter element of the 2nd filter stage is made of stainless steel wire mesh and has very low flow resistance properties. The fineness levels usual in the gear oil filtration of wind power plants are 40 µm (mesh weave: twill) and 50 µm (weave: single lacing). In the case of wire mesh elements the filter fineness is the diameter of the largest spherical particle that can just about pass through the mesh. Wire mesh elements are used in hydraulic and lubricating oil filtration as suction filters or coarse filters, with high-viscosity media as well as in safety filters in cooling lubricant filtration. Wire mesh elements have a sharp cut point as surface filters and a lower dirt pick-up capacity than depth filters.

5. Designation, ordering example and order numbers

5.1 Ordering example				
Type 852 099	Series			
	Filter material 1 st stage PS 10	Premium Select, Feinheit 10 µm		
852 099		Filter material 2 nd stage DRG 50	Wire mesh, fineness 50 µm	
	PS 10/	DRG 50/	Bypass valve V5.0	Opening pressure 5 bar
			V5.0	Ordering example

5.2 Order numbers 2-stage elements for housing/oil filter modules from Filtration Group				
Oil filter module	Designation	Order number	Filter area [cm ²]	Dirt pick-up capacity* [g]
Pi 831x	852 099 PS 6/DRG 50/V3.0	70535932	22100	450
	852 099 PS 6/DRG 50/V5.0	70534327		
	852 099 PS 10/DRG 50/V3.0	70536627		
	852 099 PS 10/DRG 50/V5.0	70514957		
	852 100 PS 6/DRG 50/V5.0	70535918	52000	1200
852 100 PS 10/DRG 50/V5.0	70517355			

Customized execution on request

5.3 Bestellnummern 2-Stufen Elemente für Gehäuse/Ölfiltermodule Wettbewerb				
Oil filter module	Designation	Order number	Filter area [cm ²]	Dirt pick-up capacity* [g]
Pi 831x	852 105 PS 10/DRG 50/V3.0	70582987	18500	380
	852 105 PS 10/DRG 50/V5.0	70583161		
	852 270 PS 10/DRG 50/V5.0	72341076	31760	730
	852 750 PS 10/DRG 50/V5.0	72359048	36860	850

* according to ISO 16889

6. Technical data

Folding star-shape	Pleated (star-pleated)
Direction of flow	from the outside to the inside
End plates and supporting tubes	Free of chromium VI
Resistance to collapse	30 bar
Operating temperature range	-10 °C to +120 °C
Seals	NBR (other materials on request)
Adhesive	Epoxy resin

Your Contact

FILCOM GmbH
Schönbuchstr. 1
D-73760 Ostfildern

Phone: +49 (0) 711-4413322-0
Fax: +49 (0) 711-4413322-22
Mail: info@filcom.de

FILCOM[®]
FILTRATION

www.filcom.de