

Low Pressure Filter

Pi 1500

Nominal pressure 10/25 bar (140/360 psi), nominal size up to 600
Filter elements according to DIN 24550

1. Features

High performance filters for modern hydraulic systems

- Provided for pipe installation
- Modular system
- Compact design
- Minimal pressure drop through optimal flow design
- Visual/electrical/electronic maintenance indicator
- Threaded connections
- Quality filters, easy to service
- Equipped with highly efficient glass fibre PS filter elements
- Beta rated elements according to ISO 16889 multipass test
- Elements with high differential pressure stability and dirt holding capacity
- Worldwide distribution



2. Flow rate/pressure drop curve complete filter

190 mm²/s
33 mm²/s

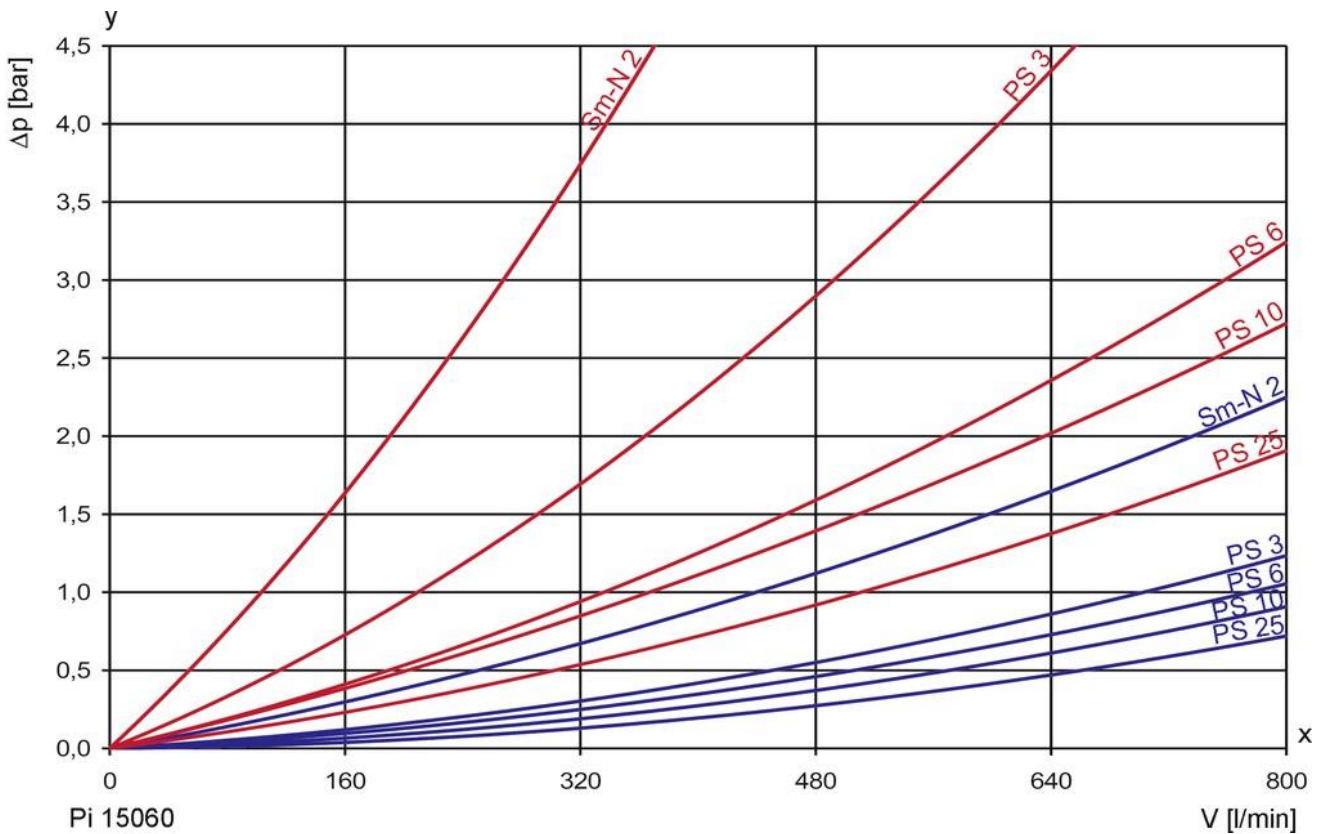
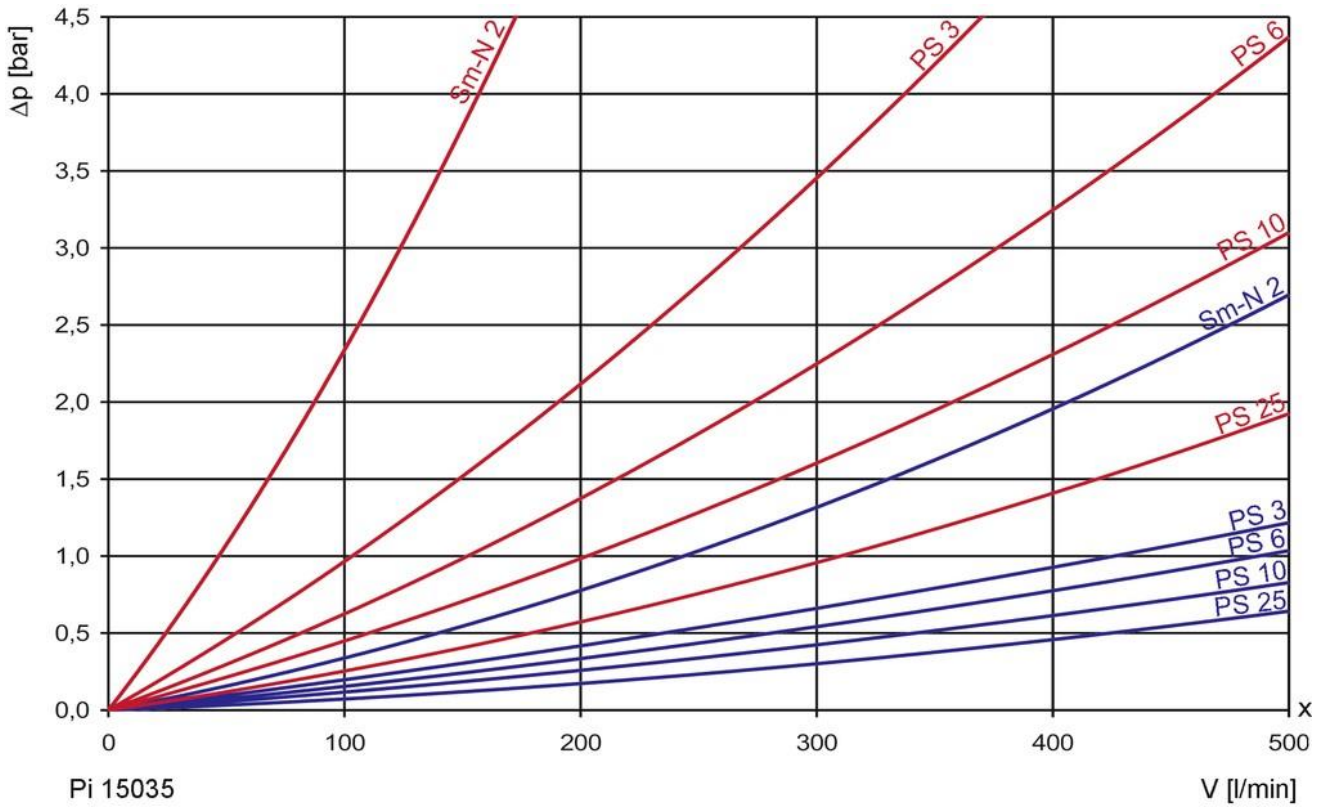

y = differential pressure Δp [bar]
x = flow rate V [l/min]

3. Separation characteristics

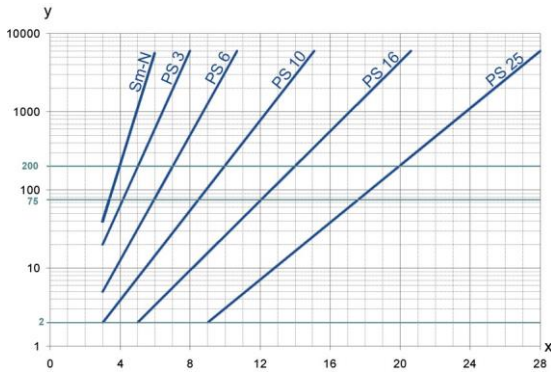

y = beta-value

x = particle size [μm]

determined by multipass tests (ISO 16889)
calibration according to ISO 11171 (NIST)

4. Filter performance data

tested according to ISO 16889 (multipass test)

PS/Sm-N 2 elements with

max. Δp 10 bar

Sm-N	2	$\beta_{4(C)} \geq 200$
PS	3	$\beta_{5(C)} \geq 200$
PS	6	$\beta_{7(C)} \geq 200$
PS	10	$\beta_{10(C)} \geq 200$
PS	16	$\beta_{15(C)} \geq 200$
PS	25	$\beta_{20(C)} \geq 200$

Values guaranteed up to 10 bar differential pressure.

The filter element Sm-N 2 is an element with a very large dirt holding capacity, especially for bypass filtration.

5. Quality assurance

Filtration Group filters and filter elements are manufactured respectively, tested in accordance with the following international standards:

Norm	Designation
DIN ISO 2941	Hydraulic fluid power filter elements; verification of collapse/burst resistance
DIN ISO 2942	Hydraulic fluid power filter elements; verification of fabrication integrity
DIN ISO 2943	Hydraulic fluid power filter elements; verification of material compatibility with fluids
DIN ISO 3723	Hydraulic fluid power filter elements; method for end load test
DIN ISO 3724	Hydraulic fluid power filter elements; verification of flow fatigue characteristics
ISO 3968	Hydraulic fluid power-filters-evaluation of pressure drop versus flow characteristics
ISO 10771.1	Fatigue pressure testing of metal containing envelopes in hydraulic fluid applications
ISO 16889	Hydraulic fluid power filters-multipass method for evaluation filtration performance of a filter element

6. Symbols

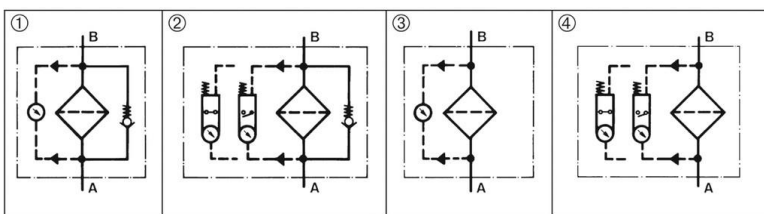

7. Order numbers

Example for ordering filters:

1. Filter housing	2. Filter element
V = 350 l/min, bypass, electrical maintenance indicator, Nominal pressure: 10 bar Type: Pi 15035/10-058 Order number: 76101778	PS 10 Type: Pi 23063 RN PS 10 Order number: 77924202

7.1 Housing design							
Nominal size NG [l/min]	Order number	Type	Nominal pressure [bar]	① with bypass valve and visual indicator	② with bypass valve and electrical indicator	③ with visual indicator	④ with electrical indicator
350	76101760	Pi 15035/10-057	10				
	76101778	Pi 15035/10-058					
	76101786	Pi 15035/10-068					
	76101794	Pi 15035/10-069					
	76101851	Pi 15035/25-057	25				
	76101869	Pi 15035/25-058					
600	76101802	Pi 15060/10-057	10				
	76101810	Pi 15060/10-058					
	76101828	Pi 15060/10-068					
	76126353	Pi 15060/10-069					
	76101877	Pi 15060/25-057	25				
	76101885	Pi 15060/25-058					

When filter with non bypass configuration is selected, the collapse pressure of the element must not be exceeded.

7.2 Filter elements*						
Nominal size NG [l/min]	Order number	Type	Filter material	Number	max. Δp [bar]	Filter surface [cm ²]
350	76112650	Pi 2S063 RN Sm-N 2	Sm-N 2	1	10	8850
	77924194	Pi 21063 RN PS 3	PS 3	1		13515
	77964091	Pi 22063 RN PS 6	PS 6	1		13515
	77924202	Pi 23063 RN PS 10	PS 10	1		13515
	77963671	Pi 24063 RN PS 16	PS 16	1		13515
	77960263	Pi 25063 RN PS 25	PS 25	1		13515
600	76112650	Pi 2S063 RN Sm-N 2	Sm-N 2	2	10	2 x 8850
	77924194	Pi 21063 RN PS 3	PS 3	2		2 x 13515
	77964091	Pi 22063 RN PS 6	PS 6	2		2 x 13515
	77924202	Pi 23063 RN PS 10	PS 10	2		2 x 13515
	77963671	Pi 24063 RN PS 16	PS 16	2		2 x 13515
	77960263	Pi 25063 RN PS 25	PS 25	2		2 x 13515

*a wider range of element types is available on request

8. Technical specifications

Nominal pressure:	10/25 bar (140/360 psi)
Temperature range:	- 10 °C to + 120 °C (other temperature ranges on request)
Bypass setting:	Δp 3.5 bar \pm 10 %
Filter head material:	GAL
Filter housing material:	St
Sealing material:	NBR
Maintenance indicator setting:	Δp 2.2 bar \pm 10 %
Electrical data of maintenance indicator:	
Maximum voltage:	250 V AC/200 V DC
Maximum current:	1 A
Contact load:	70 W
Type of protection:	IP 65 in inserted and secured status
Contact:	normally open/closed
Cable sleeve:	M20x1.5

The switching function can be changed by turning the electric upper part by 180° (normally closed contact or normally open contact). The state on delivery is a normally closed contact. By inductivity in the direct current circuit the use of suitable protection circuit should be considered. Further maintenance indicators details and designs are available in the maintenance indicator data sheet.

We draw attention to the fact that all values indicated are average values which do not always occur in specific cases of application. Our products are continually being further developed. Values, dimensions and weights can change as a result of this. Our specialized department will be pleased to offer you advice.

We recommend to contact us concerning applications of our filters in areas governed by the EU Directive 94/9 EC (ATEX 95). The standard version can be used for liquids based on mineral oil (corresponding to the fluids in Group 2 of Directive 97/23 EC Article 9). If you consider to use other fluids please contact us for additional support.

Housing with nominal pressure 10 bar are fitted standard with an air bleeder valve.

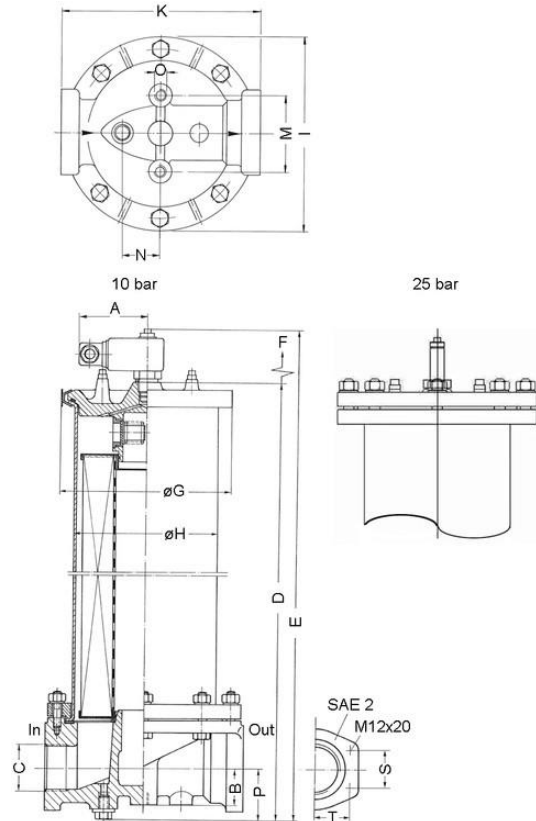

Subject to technical alteration without prior notice.

9. Dimensions

All dimensions except "C" in mm.

Type	A	B	C	D	E	F	G 10 bar	G 25 bar	H	I	K	M	N	O	P	S	T	Weight [kg]
Pi 15035	78	42	G1½	643	680	425	190	225	165	225	230	90	44	M12x20	59	-	-	17.1
Pi 15060	78	42	SAE 2	1005	1045	850	190	225	165	225	230	90	44	M12x20	59	42.9	77.8	27.1

NPT- and SAE-connections on request.

* Standard pressure series hole pattern 3000 PSI

10. Installation, operating and maintenance instructions

10.1 Filter installation

When installing filter make sure that sufficient space is available to remove filter element and filter housing.

10.2 Connecting the electrical maintenance indicator

The electrical indicator is connected via a 2-pole appliance plug according to DIN EN 175301-803 with poles marked 1 and 2. The electric upper section can be inverted to change from normally open position to normally closed position or vice versa.

10.3 When should the filter element be replaced?

1. Filters equipped with visual and electrical maintenance indicator:
During cold starts, the indicator may give a warning signal. Press the red button of the visual indicator once again only after operating temperature has been reached. If the red button immediately pops up again and/or the electrical signal has not switched off after reaching operating temperature, the filter element must be replaced after the end of the shift.
2. Filters without maintenance indicator:
The filter element should be replaced after the trial run or flushing of the system. Afterwards follow instructions of the manufacturer.
3. Please always ensure that you have original Filtration Group spare elements in stock: Disposable elements (PS, Sm-N) cannot be cleaned.

10.4 Element replacement

1. Stop system and relieve filter from pressure.
2. Loosen quick-action clamp (10 bar version) or screws of flanged cover, remove cover, and open drain valve. Housing completely vented.
3. Remove filter element from filter housing. Remove spacer sleeve at Pi 15060. After proper cleaning please use again.
4. Check seals for damage. Replace, if necessary.
5. Make sure that the part number on the spare element corresponds with the part number on the filter label. It is necessary to replace always both elements of Pi 15060. Remove the plastic bag and push element over the spigot in the filter head. Attach sleeve on Pi 15060 and fit second element.
6. 10 bar version: Close drain valve, relocate cover, and close the quick-action clamp. Filters are automatically vented via the air bleeder valve, the protection cap has to be turned 2 times for being open.
7. 25 bar version: Close drain valve and put the cover plate on so that the stud bolts go into the holes of the cover plate. Make sure not to squeeze the O-ring on the bottom side of the cover plate. Hand-tighten the 8 mounting nuts with spring rings. Then draw up the nuts tight crosswise with a turn-screw SW 19 without canting the cover plate. Tightening torque for mountings nuts is 50 Nm. After bringing the hydraulic unit to service de-aerate the filter via vent-screw.

11. Spare parts list

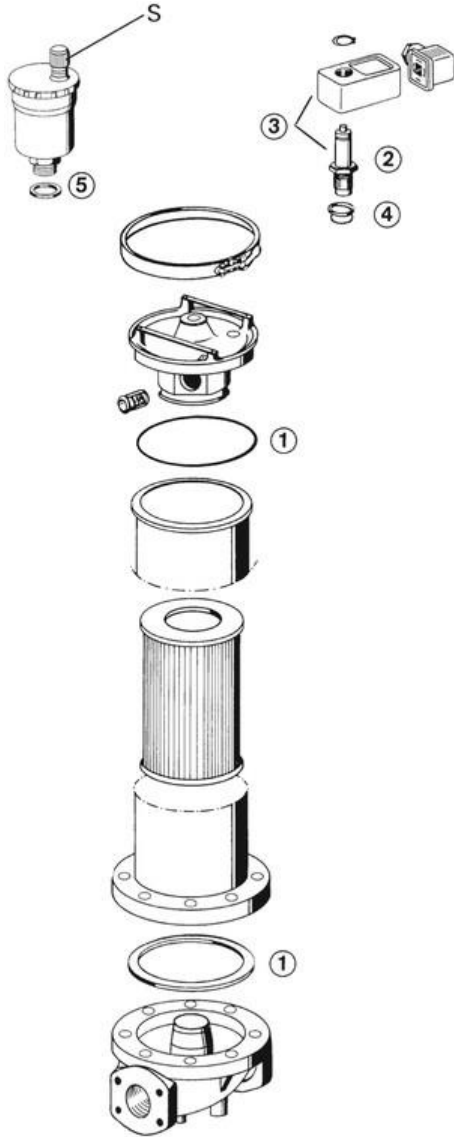

Order numbers for spare parts		
Position	Type	Order number
①	Seal kit	
	NBR	77831407
	FPM	77831415
	EPDM	77831423
② + ③	Maintenance indicator	
	Visual PiS 3098/2.2	77669971
	Electrical PiS 3097/2.2	77669948
	Electrical upper section only	77536550
④	Seal kit for differential pressure indicator PiS 3098/2.2 + PiS 3097/2.2	
	NBR	77760309
	FPM	77760317
	EPDM	77760325
⑤	Air bleeder valve	70323353
	Adapter for filter elements (Pi 15060)	76102073

Your Contact

FILCOM GmbH
Schönbuchstr. 1
D-73760 Ostfildern

Phone: +49 (0) 711-4413322-0
Fax: +49 (0) 711-4413322-22
Mail: info@filcom.de

www.filcom.de

