

Line filter Pi 1907

Nominal pressure 16 bar (230 psi), nominal size 400 up to 6000

1. Features

High performance filters for modern hydraulic systems

- Provided for pipe installation
- Modular design
- Compact design
- Minimal pressure drop through optimal flow design
- Visual/electrical/electronic maintenance indicator
- Flanged connections
- Quality filters, easy to service
- Equipped with highly efficient glass fibre PS/Sm-x filter elements
- Beta rated elements according to ISO 16889 multipass test
- Elements with high differential pressure stability and dirt holding capacity
- Worldwide distribution



2. Separation grade characteristics

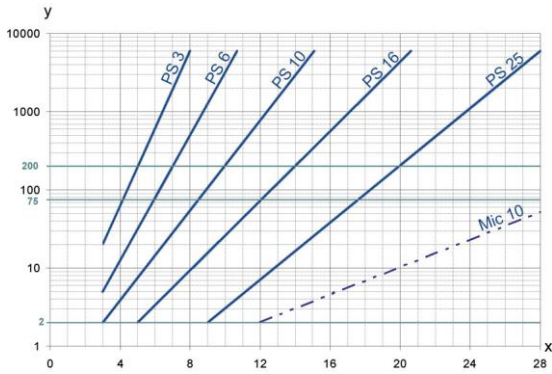

y = beta-value

x = particle size [μm]

determined by multipass tests (ISO 16889)

calibration according to ISO 11171 (NIST)

3. Filter performance data

tested according to ISO 16889 (multipass test)

PS elements with max. Δp 10 bar

PS	3	$\beta_{5(C)}$	\geq	200
PS	6	$\beta_{7(C)}$	\geq	200
PS	10	$\beta_{10(C)}$	\geq	200
PS	16	$\beta_{15(C)}$	\geq	200
PS	25	$\beta_{20(C)}$	\geq	200

values guaranteed at 5 bar differential pressure

4. Quality assurance

Filtration Group filters and filter elements are produced according to the following international standards:

Norm	Designation
DIN ISO 2941	Hydraulic fluid power filter elements; verification of collapse/burst resistance
DIN ISO 2942	Hydraulic fluid power filter elements; verification of fabrication integrity
DIN ISO 2943	Hydraulic fluid power filter elements; verification of material compatibility with fluids
DIN ISO 3723	Hydraulic fluid power filter elements; method for end load test
DIN ISO 3724	Hydraulic fluid power filter elements; verification of flow fatigue characteristics
ISO 3968	Hydraulic fluid power-filters-evaluation of pressure drop versus flow characteristics
ISO 10771.1	Fatigue pressure testing of metal containing envelopes in hydraulic fluid applications
ISO 16889	Hydraulic fluid power filters; multipass method for evaluation filtration performance of a filter element

5. Symbols

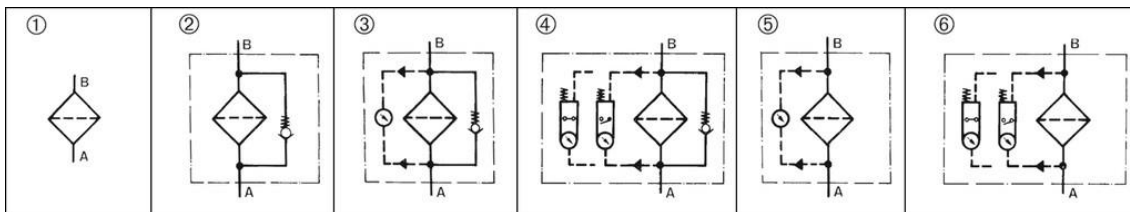

6. Types (Example for ordering filters)

Pi 1907/ 3/ 16/ 150/ V/ E/ Mg/ Abh/ 852 888 PS 10

Pi 1907	3	16	150	V	E	Mg	Abh	852888 PS 10
1	2	3	4	5	6	7	8	9

1 Filter type	
2 Number of elements	(up to DN 125, 1; DIN 150 and 200 3 ea.)
3 Nominal pressure	
4 Connection size	
5 Bypass valve	
6 Maintenance indicator	E = electrical, M = visual
7 Magnets	(available for flange size DN 100 up to DN 200)
8 Cover lifting device	(available for flange size DN 150, DN 200)
9 Filter element	

7. Technical specifications

Design:		line mounting filter
Fitting position:		preferable upright
Nominal pressure:		16 bar (NG 150 and 200 also available with operating pressure 10 bar)
Connections:	NG 400 630 800 1250 1800 3500 6000	
	DN 50 65 80 100 125 150 200	
		Flange connections according to DIN EN 1092-1
Temperature range:		- 10 °C to + 100 °C (other temperature ranges on request)
Filter housing material:		steel welded construction
Sealing material:		NBR (other material on request)
Bypass setting:		Δp 3.5 bar \pm 10 %
Maintenance indicator setting:		Δp 2.2 bar \pm 10 %
Electrical data of maintenance indicator:		
Maximum voltage:		230 V \sim /=
Maximum current:		2.5 A
Contact load:		60 VA/40 W
Inrush current:		70 VA
Type of protection:		IP 65 in inserted and secured status
Contact:		normally open/closed
Cable sleeve:		M20x1.5

The switching function can be changed by turning the electric upper part by 180° (normally closed contact or normally open contact). The state on delivery is a normally closed contact. By inductivity in the direct current circuit the use of suitable protection circuit should be considered. Further maintenance indicator details and designs are available in the maintenance indicator data sheet.

We draw attention to the fact that all values indicated are average values and do not always occur in specific cases of application. Our products are continually being further developed. Values, dimensions and weights can change as a result of this. Our specialized department will be pleased to offer you advice.

We recommend you to contact us concerning applications of our filters in areas governed by the EU Directive 94/9 EC (ATEX 95). The standard version can be used for liquids based on mineral oil (corresponding to the fluids in Group 2 of Directive 97/23 EC Article 9). If you consider to use other fluids please contact us for additional support.

8. Order numbers

8.1 Filter elements					
Nominal size NG [l/min]	Order number	Type	Filter material	max. Δp [bar]	Filter surface [cm ²]
400 DN 50	77924178	Pi 21040 RN PS 3 NBR	PS 3	10	8310
	77964083	Pi 22040 RN PS 6 NBR	PS 6		8310
	77924186	Pi 23040 RN PS 10 NBR	PS 10		8310
	77963663	Pi 24040 RN PS 16 NBR	PS 16		8310
	77960255	Pi 25040 RN PS 25 NBR	PS 25		8310
	77925050	Pi 13040 RN Mic 10 NBR	Mic 10	10	9450
	77963713	Pi 35040 RN DRG 25 NBR	DRG 25	10	6370
	77999444	Pi 36040 RN DRG 40 NBR	DRG 40		6370
	77963762	Pi 37040 RN DRG 60 NBR	DRG 60		6370
	78267833	Pi 38040 RN DRG 100 NBR	DRG 100		6370
630 DN 65	77924194	Pi 21063 RN PS 3 NBR	PS 3	10	13580
	77964091	Pi 22063 RN PS 6 NBR	PS 6		13580
	77924202	Pi 23063 RN PS 10 NBR	PS 10		13580
	77963671	Pi 24063 RN PS 16 NBR	PS 16		13580
	77960263	Pi 25063 RN PS 25 NBR	PS 25		13580
	77925068	Pi 13063 RN Mic 10 NBR	Mic 10	10	15550
	77963721	Pi 35063 RN DRG 25 NBR	DRG 25	10	8777
	77999451	Pi 36063 RN DRG 40 NBR	DRG 40		10320
	77963770	Pi 37063 RN DRG 60 NBR	DRG 60		8777
	78264459	Pi 38063 RN DRG 100 NBR	DRG 100		10320
77924194	Pi 21063 RN PS 3 NBR	PS 3	10		13580
77964091	Pi 22063 RN PS 6 NBR	PS 6		13580	
77924202	Pi 23063 RN PS 10 NBR	PS 10		13580	
77963671	Pi 24063 RN PS 16 NBR	PS 16		13580	
77960263	Pi 25063 RN PS 25 NBR	PS 25		13580	
800 DN 80	77925068	Pi 13063 RN Mic 10 NBR	Mic 10	10	15550
	77963721	Pi 35063 RN DRG 25 NBR	DRG 25	10	8777
	77999451	Pi 36063 RN DRG 40 NBR	DRG 40		10320
	77963770	Pi 37063 RN DRG 60 NBR	DRG 60		8777
	78264459	Pi 38063 RN DRG 100 NBR	DRG 100		10320
	78263295	852 888 PS 3 NBR	PS 3		10
	78354029	852 888 PS 6 NBR	PS 6	21850	
	78226813	852 888 PS 10 NBR	PS 10	21850	
	78226821	852 888 PS 25 NBR	PS 25	21850	
	1250 DN 100	78207664	852 888 Mic 10 NBR	Mic 10	10
78228017		852 888 Drg 25 NBR	DRG 25	10	16500
78228025		852 888 Drg 40 NBR	DRG 40		16500
78303026		852 888 Drg 60 NBR	DRG 60		16500
78228470		852 888 Drg 100 NBR	DRG 100		16500

8.1 Filter elements					
Nominal size NG [l/min]	Order number	Type	Filter material	max. Δ p [bar]	Filter surface [cm ²]
1800 DN 125	78227431	852 884 PS 3 NBR	PS 3	10	28500
	79337916	852 884 PS 6 NBR	PS 6		28500
	78226797	852 884 PS 10 NBR	PS 10		28500
	78226805	852 884 PS 25 NBR	PS 25		28500
	70366315	852 884 Mic 10 NBR	Mic 10	10	28500
	79337460	852 884 Drg 25 NBR	DRG 25	10	23450
	78261653	852 884 Drg 40 NBR	DRG 40		23450
	79700402	852 884 Drg 60 NBR	DRG 60		23450
	79327750	852 884 Drg 100 NBR	DRG 100		23450
3500 DN 150	78263295	3x 852 888 PS 3 NBR	PS 3	10	65550
	78354029	3x 852 888 PS 6 NBR	PS 6		65550
	78226813	3x 852 888 PS 10 NBR	PS 10		65550
	78226821	3x 852 888 PS 25 NBR	PS 25		65550
	78207664	3x 852 888 Mic 10 NBR	Mic 10	10	65550
	78228017	3x 852 888 DRG 25 NBR	DRG 25	10	49500
	78228025	3x 852 888 DRG 40 NBR	DRG 40		49500
	78303026	3x 852 888 DRG 60 NBR	DRG 60		49500
	78228470	3x 852 888 DRG 100 NBR	DRG 100		49500
6000 DN 200	78227431	3x 852 884 PS 3 NBR	PS 3	10	85506
	79337916	3x 852 884 PS 6 NBR	PS 6		85506
	78226797	3x 852 884 PS 10 NBR	PS 10		85506
	78226805	3x 852 884 PS 25 NBR	PS 25		85506
	70366315	3x 852 884 Mic 10 NBR	Mic 10	10	85500
	79337460	3x 852 884 DRG 25 NBR	DRG 25	10	70350
	78261653	3x 852 884 DRG 40 NBR	DRG 40		70350
	79700402	3x 852 884 DRG 60 NBR	DRG 60		70350
	79327750	3x 852 884 DRG 100 NBR	DRG 100		70350

9. Dimensions

All dimensions in mm.

Nominal size NG [l/min]	Connection DN	Nominal pressure PN [bar]	A	B	C	D	E	G	H	J	K
			400	50	16	285	169	890	250	380	G½
630	65	285	169	890		250	380	G½	110	300	350
800	80	285	169	890		250	380	G½	110	300	350
1250	100	340	220	1200		365	450	G½	195	380	450
1800	125	405	273	1200		435	500	G½	240	450	450
3500	150	580	407	1530		600	690	G1	300	440	450
6000	200	715	508	1465		550	740	G1	170	500	450
3500	150	10	565	407	1530	600	690	G1	300	440	450
6000	200		670	508	1465	550	740	G1	170	500	450

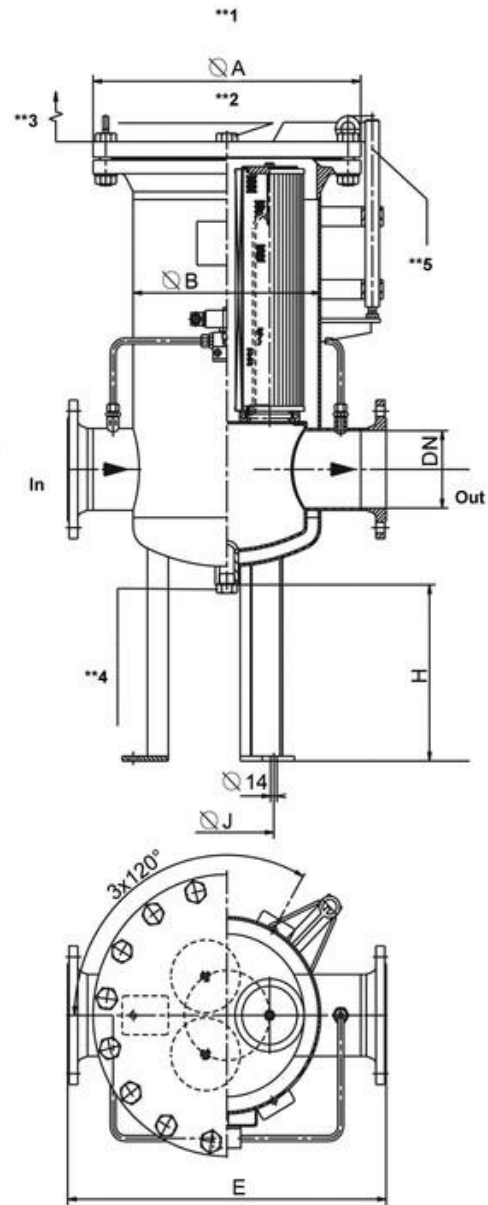
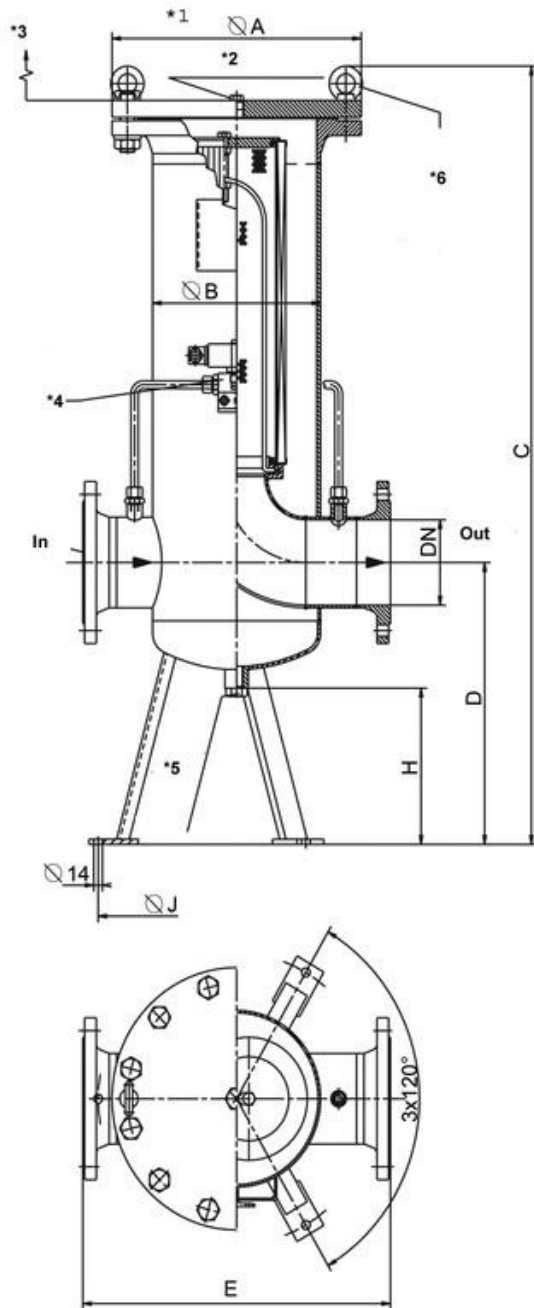

- *1 illustration shows execution up to flange size DN 125
- *2 vent screw
- *3 "K" height required for element removal
- *4 maintenance indicator visual/electrical
- *5 drain plug dirt side "G"
- *6 Lifting eye; available for versions starting with size DN 100

- **1 illustration shows execution starting with flange size DN 150
- **2 vent screw
- **3 "K" height required for element removal
- **4 drain plug dirt side "G"
- **5 cover lifting device

10. Commissioning

- Prior to commissioning the filter open the venting screw and wait until liquid emerges. Then tighten the venting screw.
- After that all sealing points must be optically inspected for leaks.
- If the maintenance indicator gives a signal when the operating temperature has been reached, the filter element must be exchanged after the end of the shift.
- For element exchange stop system and relieve filter from pressure. Empty filter over drain plug, remove hex nuts, remove container top, remove hex nut, remove valve plate, remove nut, remove filter element.
- Clean filter housing using a suitable medium.
- Clean contaminated filter elements or replace by new MAHLE filters (only Drg-elements are cleanable).
- Inspect all sealing points and seals and replace by new if required.
- Assembly is performed in reverse order.

Your Contact

FILCOM GmbH
 Schönbuchstr. 1
 D-73760 Ostfildern

www.filcom.de

Phone: +49 (0) 711-4413322-0
 Fax: +49 (0) 711-4413322-22
 Mail: info@filcom.de

FILCOM[®]
 FILTRATION