

Low Pressure Filter

Pi 2000/Pi 2200

Nominal pressure 25 bar (360 psi), nominal size 630 up to 2000
according to DIN 24550

1. Features

High performance filters for modern hydraulic systems

- Modular system
- Compact design
- Minimal pressure drop through optimal flow design
- Visual/electrical, electronic maintenance indicator
- Flanged connections
- Quality filters, easy to service
- Equipped with highly efficient glass fibre PS filter elements
- Beta rated elements according to ISO 16889 multipass test
- Elements with high differential pressure stability and dirt holding capacity
- Worldwide distribution



2. Flow rate/pressure drop curve complete filter

■ 190 mm²/s
■ 33 mm²/s

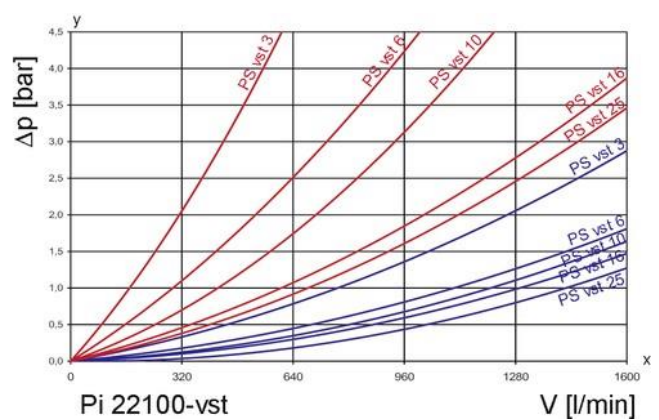
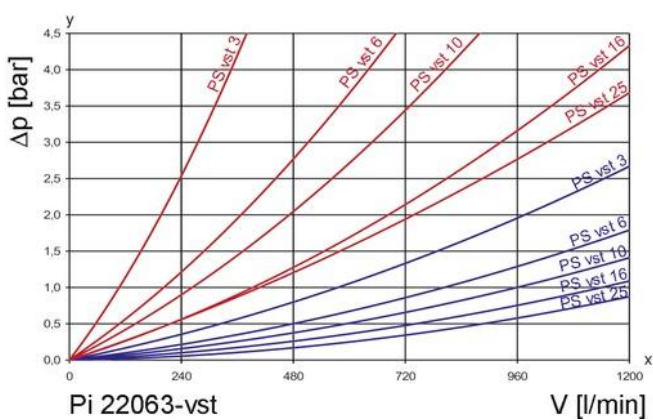
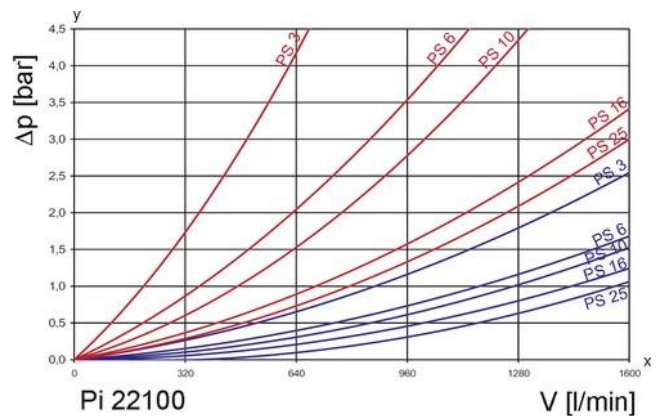
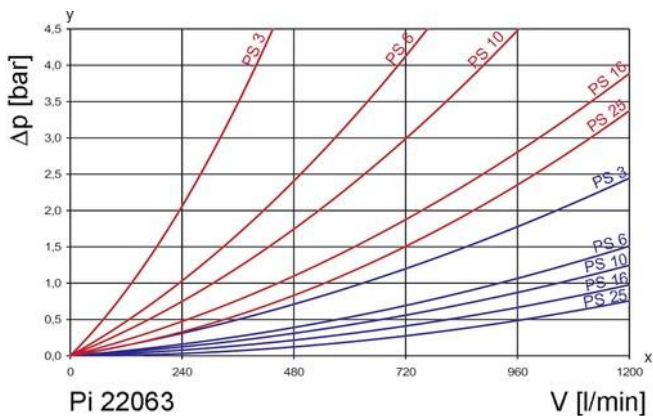
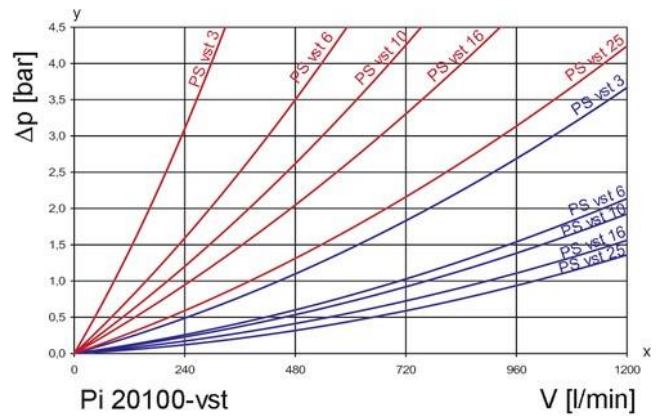
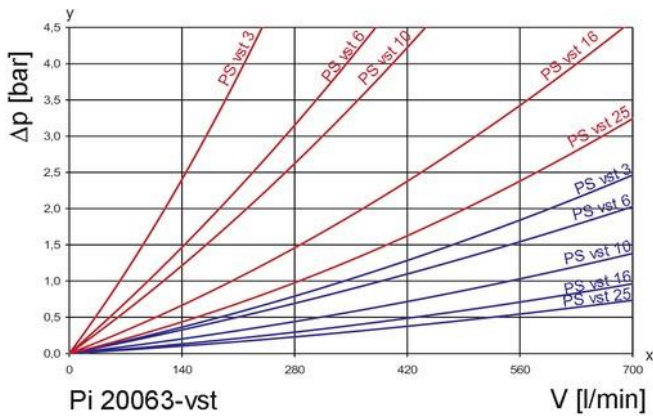
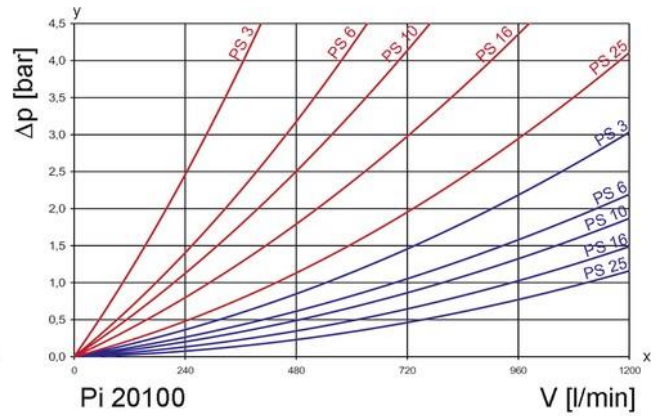
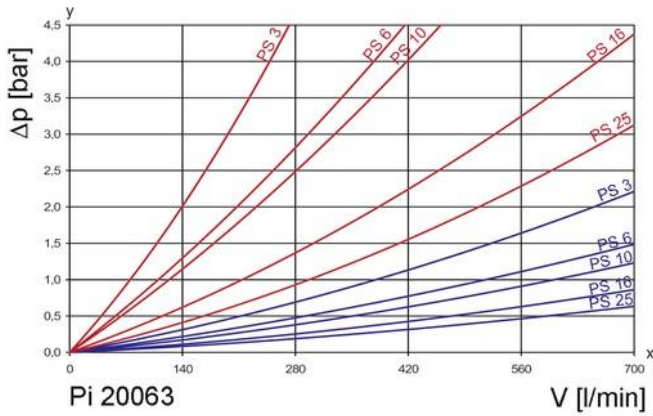

y = differential pressure Δp [bar]

x = flow rate V [l/min]

3. Separation grade characteristics

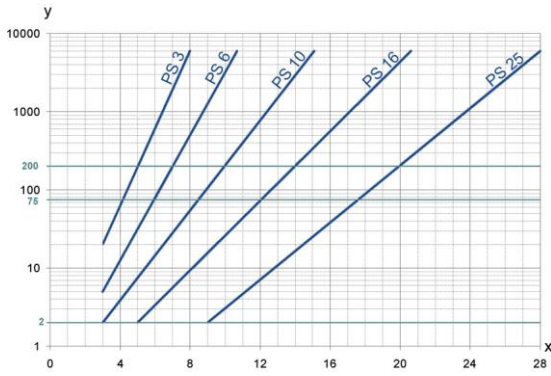

y = beta-value
x = particle size [µm]

determined by multipass tests (ISO 16889)
calibration according to ISO 11171 (NIST)

4. Filter performance data

tested according to ISO 16889 (multipass test)

PS elements with
max. Δ p 20 bar

PS	3	$\beta_{5(C)} \geq 200$
PS	6	$\beta_{7(C)} \geq 200$
PS	10	$\beta_{10(C)} \geq 200$
PS	16	$\beta_{15(C)} \geq 200$
PS	25	$\beta_{20(C)} \geq 200$

values guaranteed at
10 bar differential pressure

PS vst elements with
max. Δ p 210 bar

PS vst	3	$\beta_{5(C)} \geq 200$
PS vst	6	$\beta_{7(C)} \geq 200$
PS vst	10	$\beta_{10(C)} \geq 200$
PS vst	16	$\beta_{15(C)} \geq 200$
PS vst	25	$\beta_{20(C)} \geq 200$

values guaranteed at
20 bar differential pressure

5. Quality assurance

Filtration Group filters and filter elements are produced according to the following international standards:

Norm	Designation
DIN ISO 2941	Hydraulic fluid power filter elements; verification of collapse/burst resistance
DIN ISO 2 942	Hydraulic fluid power filter elements; verification of fabrication integrity
DIN ISO 2 943	Hydraulic fluid power filter elements; verification of material compatibility
DIN ISO 3 723	Hydraulic fluid power filter elements; method for end load test
DIN ISO 3 724	Hydraulic fluid power filter elements; verification of flow fatigue characteristics
ISO 3 968	Hydraulic fluid power-filters-evaluation of pressure drop versus flow characteristics
ISO 10 771.1	Fatigue pressure testing of metal containing envelopes in hydraulic fluid applications
ISO 16 889	Hydraulic fluid power filters-multi-passmethod for evaluation filtration performance of a filter element

6. Symbols

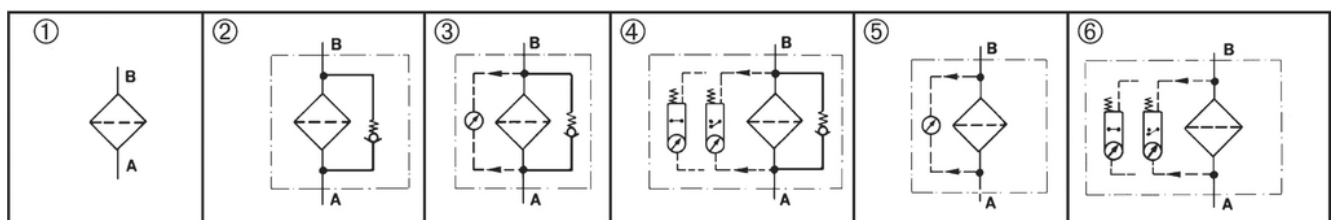

7. Order numbers

Example for ordering filters:

1. Housing design	2. Filter element (2 elements required for parallel arrangement)
V = 630 l/min and electrical maintenance indicator Type: Pi 20063-69 Order number: 77965510	PS vst 25 Type: Pi 75063 DN PS vst 25 Order number: 77961568

7.1 Housing design									
Design	Nominal size NG [l/min]	Order number	Type	① no options	② with bypass valve	③ with bypass valve and visual indicator	④ with bypass valve and electrical indicator	⑤ with visual indicator	⑥ with electrical indicator
Line filter single	630	77965478	Pi 20063-060						
		77965486	Pi 20063-056						
		77965494	Pi 20063-057						
		77964497	Pi 20063-058						
		77965502	Pi 20063-068						
		77965510	Pi 20063-069						
	1000	77965577	Pi 20100-060						
		77965585	Pi 20100-056						
		77965593	Pi 20100-057						
		77974769	Pi 20100-058						
		77965601	Pi 20100-068						
		77965619	Pi 20100-069						
Line filter parallel	1260	77965387	Pi 22063-060						
		77965676	Pi 22063-056						
		77965684	Pi 22063-057						
		77965692	Pi 22063-058						
		77965700	Pi 22063-068						
		77965718	Pi 22063-069						
	2000	77965775	Pi 22100-060						
		77965783	Pi 22100-056						
		77965791	Pi 22100-057						
		77965809	Pi 22100-058						
		77965817	Pi 22100-068						
		77965825	Pi 22100-069						

When filter with non bypass configuration is selected, the collapse pressure of the element must not be exceeded.

7.2 Filter elements*

Nominal size NG [l/min]	Order number	Type	Filter material	max. Δp [bar]	Filter surface [cm ²]
630	77961519	Pi 21063 DN PS 3	PS 3	20	9300
	77943699	Pi 22063 DN PS 6	PS 6		9300
	77925639	Pi 23063 DN PS 10	PS 10		9300
	77961527	Pi 24063 DN PS 16	PS 16		9300
	77961535	Pi 25063 DN PS 25	PS 25		9300
	210	77961543	Pi 71063 DN PS vst 3	PS vst 3	7490
		77960099	Pi 72063 DN PS vst 6	PS vst 6	7490
		77925712	Pi 73063 DN PS vst 10	PS vst 10	7490
		77961550	Pi 74063 DN PS vst 16	PS vst 16	7490
		77961568	Pi 75063 DN PS vst 25	PS vst 25	7490
1000	77961618	Pi 21100 DN PS 3	PS 3	20	14690
	77943723	Pi 22100 DN PS 6	PS 6		14690
	77925647	Pi 23100 DN PS 10	PS 10		14690
	77961626	Pi 24100 DN PS 16	PS 16		14690
	77961634	Pi 25100 DN PS 25	PS 25		14690
	210	77961642	Pi 71100 DN PS vst 3	PS vst 3	11700
		77960081	Pi 72100 DN PS vst 6	PS vst 6	11700
		77925720	Pi 73100 DN PS vst 10	PS vst 10	11700
		77961659	Pi 74100 DN PS vst 16	PS vst 16	11700
		77961667	Pi 75100 DN PS vst 25	PS vst 25	11700
1260	77961519	Pi 21063 DN PS 3	PS 3	20	2x9300
	77943699	Pi 22063 DN PS 6	PS 6		2x9300
	77925639	Pi 23063 DN PS 10	PS 10		2x9300
	77961527	Pi 24063 DN PS 16	PS 16		2x9300
	77961535	Pi 25063 DN PS 25	PS 25		2x9300
	210	77961543	Pi 71063 DN PS vst 3	PS vst 3	2x7490
		77960099	Pi 71063 DN PS vst 6	PS vst 6	2x7490
		77925712	Pi 72063 DN PS vst 10	PS vst 10	2x7490
		77961550	Pi 73063 DN PS vst 16	PS vst 16	2x7490
		77961568	Pi 74063 DN PS vst 25	PS vst 25	2x7490
2000	77961618	Pi 21100 DN PS 3	PS 3	20	2x14690
	77943723	Pi 22100 DN PS 6	PS 6		2x14690
	77925647	Pi 23100 DN PS 10	PS 10		2x14690
	77961626	Pi 24100 DN PS 16	PS 16		2x14690
	77961634	Pi 25100 DN PS 25	PS 25		2x14690
	210	77961642	Pi 71100 DN PS vst 3	PS vst 3	2x11700
		77960081	Pi 72100 DN PS vst 6	PS vst 6	2x11700
		77925720	Pi 73100 DN PS vst 10	PS vst 10	2x11700
		77961659	Pi 74100 DN PS vst 16	PS vst 16	2x11700
		77961667	Pi 75100 DN PS vst 25	PS vst 25	2x11700

* a wider range of element types is available on request

8. Technical specifications

Design:	in-line filter
Nominal pressure:	25 bar (360 psi)
Test pressure:	32 bar (460 psi)
Temperature range:	-10 °C to +120 °C (other temperature ranges on request)
Bypass setting:	Δp 3.5 bar \pm 10 %
Filter head material:	GAL
Filter housing material:	AL
Sealing material:	NBR/AL
Maintenance indicator setting:	Δp 2.2 bar \pm 0.3 bar
Electrical data of maintenance indicator:	
Maximum voltage:	250 V AC/200 V DC
Maximum current:	1 A
Contact load:	70 W
Type of protection:	IP 65 in inserted and secured status
Contact:	normally open/closed
Cable sleeve:	M20x1.5

The switching function can be changed by turning the electric upper part by 180° (normally closed contact or normally open contact). The state on delivery is a normally closed contact. By inductivity in the direct current circuit the use of suitable protection circuit should be considered. Further maintenance indicator details and designs are available in the maintenance indicator data sheet.

We draw attention to the fact that all values indicated are average values and do not always occur in specific cases of application. Our products are continually being further developed. Values, dimensions and weights can change as a result of this. Our specialized department will be pleased to offer you advice.

We recommend you to contact us concerning applications of our filters in areas governed by the EU Directive 94/9 EC (ATEX 95). The standard version can be used for liquids based on mineral oil (corresponding to the fluids in Group 2 of Directive 97/23 EC Article 9). If you consider to use other fluids please contact us for additional support.

Due to the modular system, filter can be easily converted from single type into parallel type.

Subject to technical alteration without prior notice.

9. Dimensions

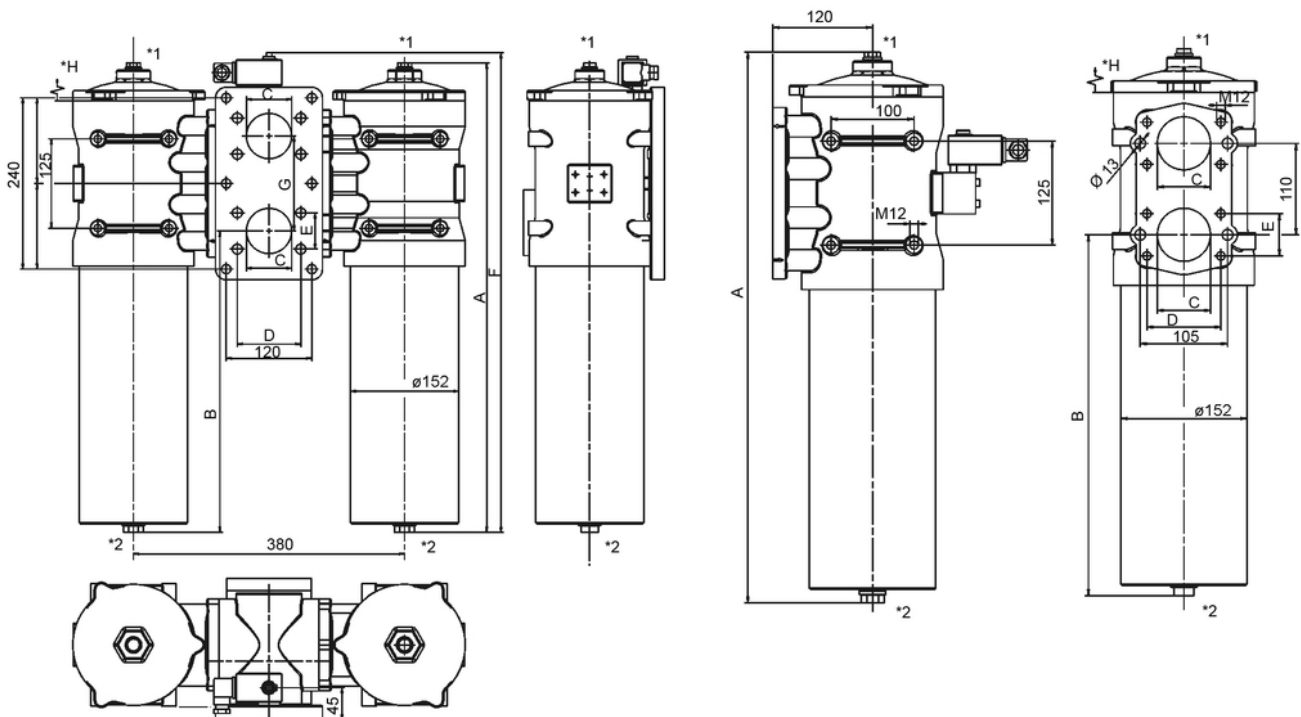

- *1 = Vent screw G3/8
- *2 = Drain plug G $\frac{3}{4}$ DIN 910
- *H = Minimum clearance for filter element removal

All dimensions in mm.

Type	A	B	C	D	E	F	G	H	Weight [kg]
Pi 20063	659	434	DN64	89	50.8	-	110	400	12.5
Pi 20100	889	664	DN64	89	50.8	-	110	630	15.0
Pi 22063	659	434	DN76	106	61.9	674	133	400	30.0
Pi 22100	889	664	DN76	106	61.9	904	133	630	35.0

10. Installation, operating and maintenance instructions

10.1 Filter installation

When installing the filter make sure that sufficient space is available to remove filter element and filter housing.

Preferably the filter should be installed with the filter housing pointing downwards.

The maintenance indicator must be visible.

10.2 Connecting the electrical maintenance indicator

The electrical indicator is connected via a 2-pole appliance plug according to DIN 43650 with poles marked 1 and 2.

The electrical section can be inverted to change from normally open position to normally closed position or vice versa.

10.3 When should the filter element be replaced?

- Filters equipped with visual and electrical maintenance indicator:
During cold starts, the indicator may give a warning signal. Press the red button of the visual indicator once again only after operating temperature has been reached. If the red button immediately pops up again and/or the electrical signal has not switched off after reaching operating temperature, the filter element must be replaced after the end of the shift.
- Filters without maintenance indicator:
The filter element should be replaced after trial run or flushing of the system. Afterwards follow instructions of the manufacturer.
- Please always ensure that you have original Filtration Group spare elements in stock: Disposable elements (PS) cannot be cleaned.

10.4 Element replacement

- Stop system and relieve filter from pressure.
- Open venting screw in filter cover (ascertain switching lever position with duplex filter and carefully check which filter housing is under pressure).
- Remove drain plug in housing bottom and drain oil.
- Unscrew filter cover (CCW).
- Lift out filter element.
- Check seal on filter cover. We recommend replacement in any case.
- Make sure that the order number on the spare element corresponds to the order number of the filter name-plate. Remove packaging and place element closed end downward into filter housing.
- Carefully insert element holding fixture of the filter cover into the open end of the element and tighten cover against stop.
- Close drain plug on housing bottom.
- Carefully vent filter prior operation. Then tighten venting screw.

Additional remark: For cleaning purposes the filter housing can be removed by unscrewing counter-clockwise.

Please change both elements at the parallel type.

11. Spare parts list

Order numbers for spare parts		
Position	Type	Order number
①	Seal kit for filter housing (duplex or parallel filter 2 sets required)	
	NBR	77967433
	FPM	77967441
	EPDM	77967458
②	Seal kit for parallel unit	
	NBR	79350984
	FPM	79350992
	EPDM	79351008
③	Maintenance indicator	
	Visual PiS 3098/2.2 bar	77669971
	Electrical PiS 3097/2.2 bar	77669948
	Electrical upper part only	77536550
④	Seal kit for maintenance indicator	
	NBR	77760309
	FPM	77760317
	EPDM	77760325
⑤	Parallel unit (for parallel filter modification)	77974876

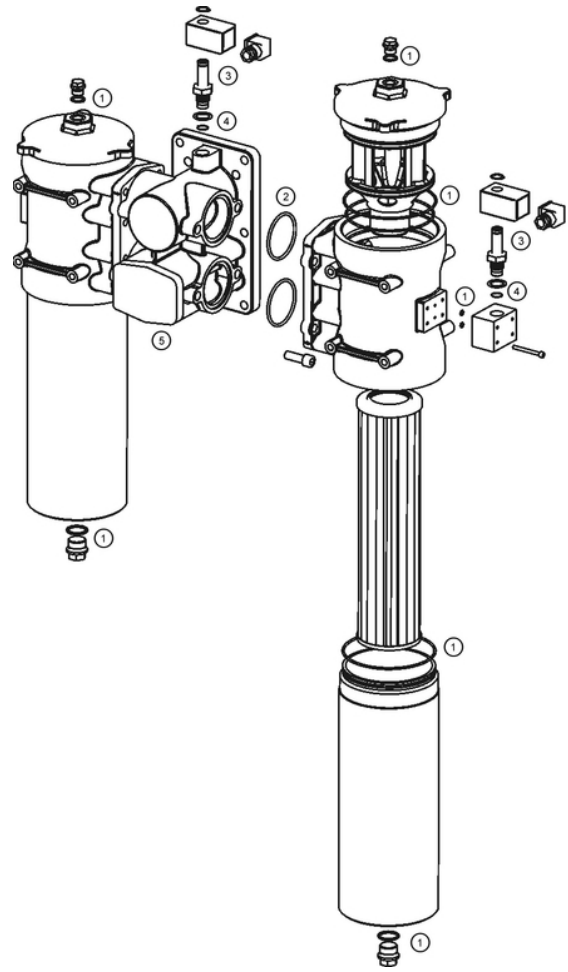

Your Contact

FILCOM GmbH
Schönbuchstr. 1
D-73760 Ostfildern

Phone: +49 (0) 711-4413322-0
Fax: +49 (0) 711-4413322-22
Mail: info@filcom.de

www.filcom.de

FILCOM[®]
FILTRATION