

Low Pressure Filter Pi 2300

Nominal pressure 25/40 bar (360/570 psi), nominal size up to 1200
Filter elements according DIN 24550

1. Features

High performance filters for modern hydraulic systems

- Provided for pipe installation
- Modular system
- Compact design
- Minimal pressure drop through optimal flow design
- Visual/electrical, electronic maintenance indicator
- Quality filters, easy to service
- Equipped with highly efficient PS filter elements
- Beta rated elements according to ISO 16889
- Elements with high differential pressure stability and dirt holding capacity
- Worldwide distribution



2. Flow rate/pressure drop curve (filter housing incl. element)

■ 190 mm²/s
■ 33 mm²/s

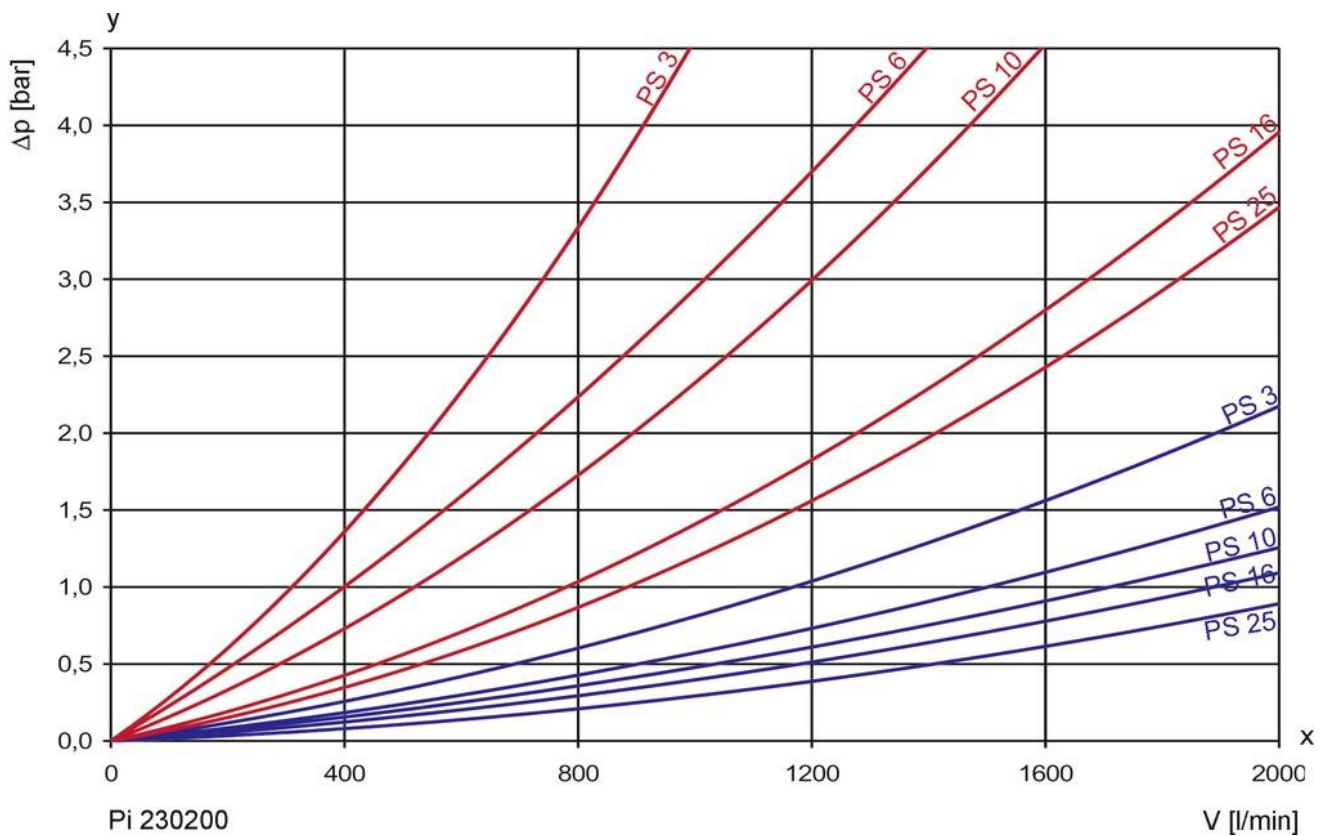
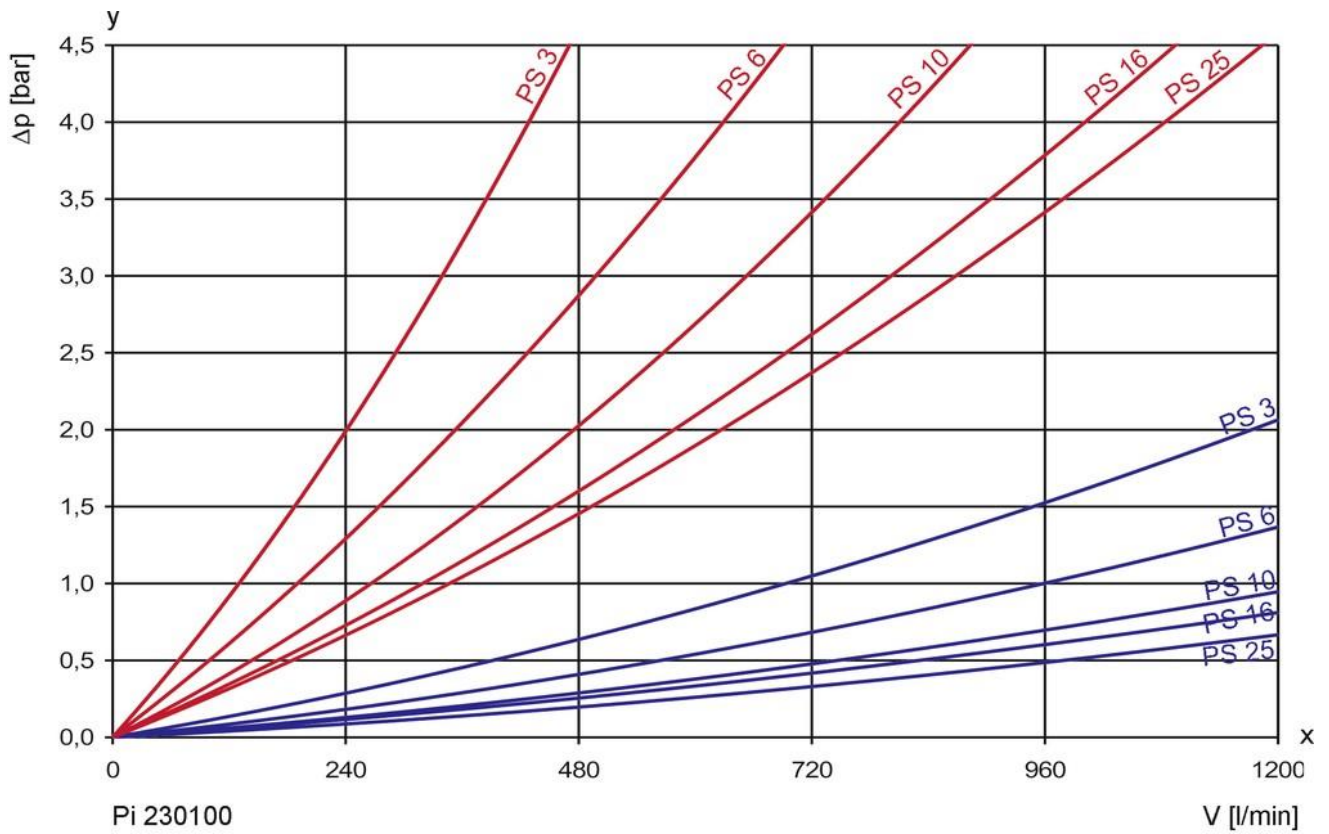

y = differential pressure Δp [bar]

x = flow rate V [l/min]

3. Separation grade characteristics

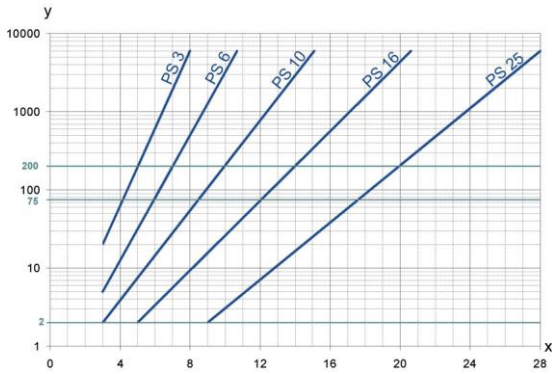

y = beta-value
x = particle size [μm]

determined by multipass tests (ISO 16889)
calibration according to ISO 11171 (NIST)

4. Filter performance data

tested according to ISO 16889 (multipass test)

PS elements with
max. Δp 10 bar

PS	3	$\beta_{5(C)}$	\geq	200
PS	6	$\beta_{7(C)}$	\geq	200
PS	10	$\beta_{10(C)}$	\geq	200
PS	16	$\beta_{15(C)}$	\geq	200
PS	25	$\beta_{20(C)}$	\geq	200

values guaranteed up to
10 bar differential pressure

5. Quality assurance

Filtration Group filters and filter elements are produced according to the following international standards:

Norm	Designation
DIN ISO 2941	Hydraulic fluid power filter elements; verification of collapse/burst resistance
DIN ISO 2942	Hydraulic fluid power filter elements; verification of fabrication integrity
DIN ISO 2943	Hydraulic fluid power filter elements; verification of material compatibility with fluids
DIN ISO 3723	Hydraulic fluid power filter elements; method for end load test
DIN ISO 3724	Hydraulic fluid power filter elements; verification of flow fatigue characteristics
ISO 3968	Hydraulic fluid power filters; evaluation of pressure drop versus flow characteristics
ISO 10771.1	Fatigue pressure testing of metal containing envelopes in hydraulic fluid applications
ISO 16889	Hydraulic fluid power filters; multipass method for evaluation filtration performance of a filter element

6. Symbols

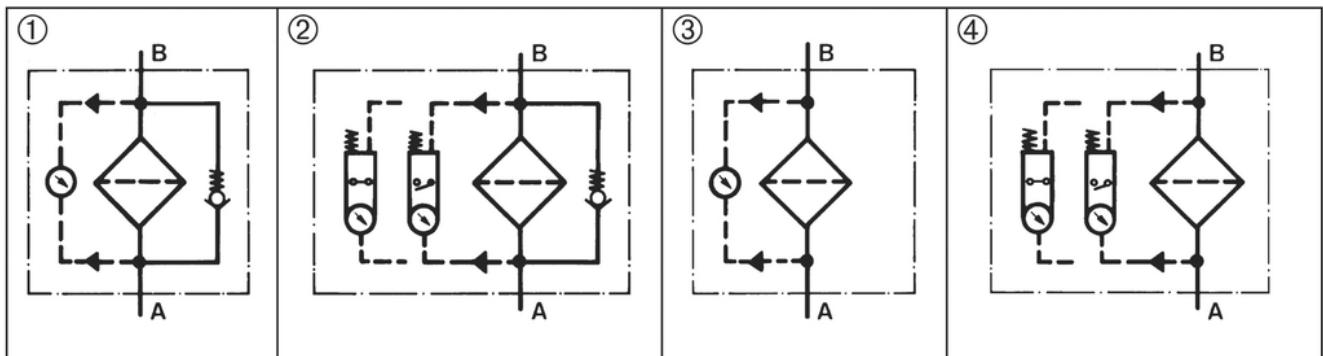

7. Order numbers

Example for ordering filters:

1. Housing design	2. Filter elements
Nominal size 750, with bypass, electrical maintenance indicator, inlet at the bottom Type: Pi 230100/11-058 Order number: 76321129	PS 10 Type: 23100 RN PS 10 Order number: 77924228 Attention: At a nominal size of 1200, 2 filter elements per housing are required

7.1 Housing design							
Nominal size NG [l/min]	Order number	Type	Inlet	① with bypass valve and visual indicator	② with bypass valve and electrical indicator	③ with visual indicator	④ with electrical indicator
750	76321087	Pi 230100/11-057	at the bottom				
	76321129	Pi 230100/11-058					
	76321160	Pi 230100/11-068					
	76321202	Pi 230100/11-069					
750	76321095	Pi 230100/21-057	at the sight				
	76321137	Pi 230100/21-058					
	76321178	Pi 230100/21-068					
	76321210	Pi 230100/21-069					
1200	76321103	Pi 230200/11-057	at the bottom				
	76321145	Pi 230200/11-058					
	76321186	Pi 230200/11-068					
	76321228	Pi 230200/11-069					
1200	76321111	Pi 230200/21-057	at the sight				
	76321152	Pi 230200/21-058					
	76321194	Pi 230200/21-068					
	76321236	Pi 230200/21-069					

When using filter with non bypass configuration is selected, the collapse pressure of the element must not be exceeded.

7.2 Filter elements*					
Nominal size NG [l/min]	Order number	Type	Filter material	Collapse pressure [bar]	Filter surface [cm ²]
750	77924210	Pi 21100 RN PS 3	PS 3	10	18760
	77964109	Pi 22100 RN PS 6	PS 6		18760
	77924228	Pi 23100 RN PS 10	PS 10		18760
	77963689	Pi 24100 RN PS 16	PS 16		18760
	77960271	Pi 25100 RN PS 25	PS 25		18760
1200	77924210	Pi 21100 RN PS 3	PS 3	10	2 x 18760
	77964109	Pi 22100 RN PS 6	PS 6		2 x 18760
	77924228	Pi 23100 RN PS 10	PS 10		2 x 18760
	77963689	Pi 24100 RN PS 16	PS 16		2 x 18760
	77960271	Pi 25100 RN PS 25	PS 25		2 x 18760

* a wider range of element types is available on request

8. Technical specifications

Nominal pressure (10 LW):	25 bar (360 psi)
Test pressure (statical):	40 bar (570 psi)
Temperature range:	-10 °C to +120 °C (other temperature ranges on request)
Bypass setting:	Δp 3.5 bar \pm 10 %
Filter head material:	GAL
Filter housing material:	AL
Sealing material:	NBR
Maintenance indicator setting	Δp 2.2 bar \pm 0.3 bar
Electrical data of maintenance indicator:	
Max. voltage:	250 V AC/200 V DC
Max. current:	1 A
Contact load:	70 W
Type of protection:	IP 65 in inserted and secured status
Contact:	normally open/closed
Cable sleeve:	M20x1.5

The switching function can be changed by turning the electric upper part by 180° (normally closed contact or normally open contact). The state on delivery is a normally closed contact. By inductivity in the direct current circuit the use of suitable protection circuit should be considered. Further maintenance indicator details and designs are available in the maintenance indicator data sheet.

We draw attention to the fact that all values indicated are average values and do not always occur in specific cases of application. Our products are continually being further developed. Values, dimensions and weights can change as a result of this. Our specialized department will be pleased to offer you advice.

We recommend you to contact us concerning applications of our filters in areas governed by the EU Directive 94/9 EC (ATEX 95). The standard version can be used for liquids based on mineral oil (corresponding to the fluids in Group 2 of Directive 97/23 EC Article 9). If you consider to use other fluids please contact us for additional support.

Subject to technical alteration without prior notice.

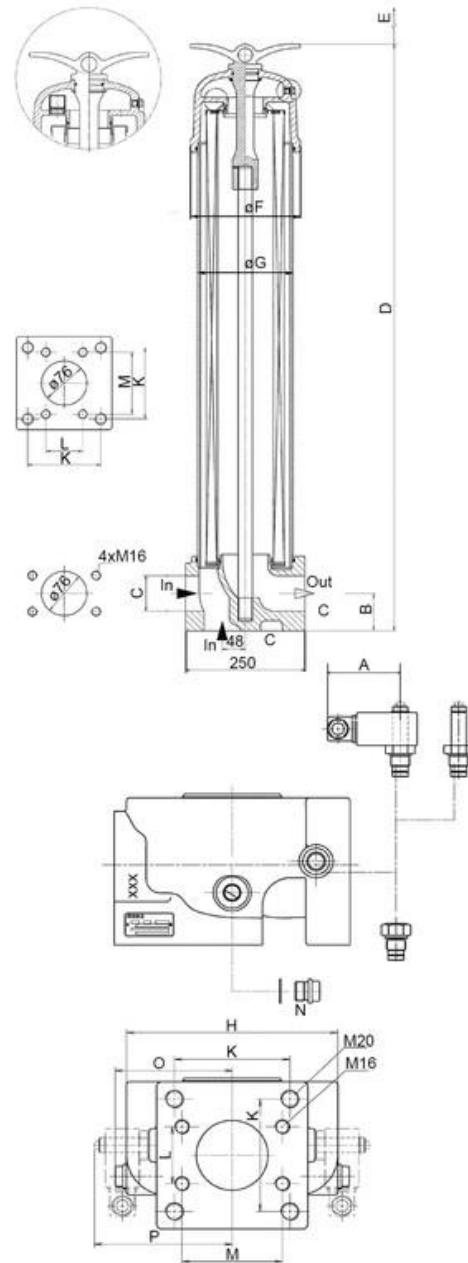

In = Inlet
Out = Outlet

9. Dimensions

All dimensions except "C" und "N" in mm

Type	A	B	C	D	E	F	G	H	K	L	M	N	O	P	Weight [kg]
Pi 230100	78	80	SAE 3, 3000 psi	710	770	230	200	224	122.3	61.9	106.6	G½	124	146	29
Pi 230200	78	80	SAE 3, 3000 psi	1260	770	230	200	224	122.3	61.9	106.6	G½	124	146	30

NPT- and SAE-connections on request

10. Installation, operating and maintenance instructions

10.1 Filter installation

When installing filter make sure that sufficient space is available to remove filter element and filter housing. Preferably the filter should be installed with the filter housing pointing upwards. The maintenance indicator must be visible.

10.2 Connecting the electrical maintenance indicator

The electrical indicator is connected via a 2-pole appliance plug according to DIN EN 175301-803 with poles marked 1 and 2. The electrical section can be inverted to change from normally open to normally closed position or vice versa.

10.3 When should the filter element be replaced?

- Filters equipped with visual and electrical maintenance indicator:
During cold starts, the indicator may give a warning signal. Press the red button of the visual indicator once again only after operating temperature has been reached. If the red button immediately pops up again and/or the electrical signal has not switched off after reaching operating temperature. The filter element must be replaced after the end of the shift.
- Filters without maintenance indicator:
The filter element should be replaced after trial run or flushing of the system. Afterwards follow instructions of the manufacturer.
- Please always ensure that you have original Filtration Group spare elements in stock: Disposable elements (PS) cannot be cleaned.

10.4 Element replacement

- Stop system and relieve filter from pressure.
- Loosen toggle, remove cover, and open drain valve. Housing completely vented.
- Remove filter element from the filter bowl. With filter type Pi 230200 remove the spacer sleeve from the elements clean and reuse.
- Check seals for damages. Replace, if necessary.
- Make sure that the part number on the spare element corresponds with the part number on the filter name-plate. With the filter type Pi 230200 always change both elements. Remove the plastic bag and push element over spigot in the filter head. With filter type Pi 320200 put the sleeve on the element. On this, telescope the second element and locate it.
- Close drain valve. Put the thumb screw together with the cover on the centre rod and tighten strong. Filter must be bled!

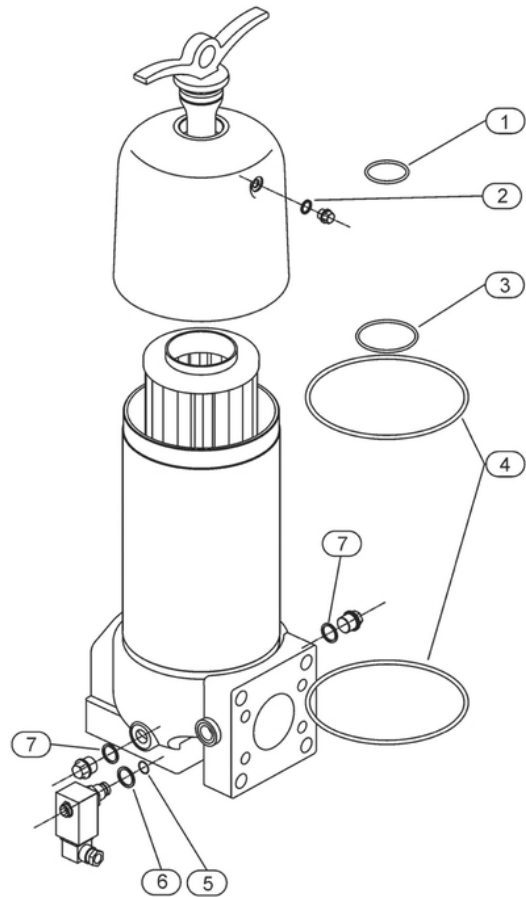

11. Spare parts list

Order numbers for spare parts		
Position	Type	Order number
①②③④⑦	Seal kit	
	NBR	76321244
	FPM	76321251
	EPDM	76321269
	Maintenance indicator	
	Visual PiS 3098/2.2	77669971
	Visual/electrical PiS 3097/2.2	77669948
	Electrical upper section only	77536550
⑤⑥	Seal kit for maintenance indicator PiS 3098/2.2 + PiS 3097/2.2	
	NBR	77760300
	FPM	77760317
	EPDM	77760325
not illustrated	Adapter for elements at Pi 230200	76937791

Your Contact

FILCOM GmbH
Schönbuchstr. 1
D-73760 Ostfildern

www.filcom.de

Phone: +49 (0) 71 1-4413322-0
Fax: +49 (0) 71 1-4413322-22
Mail: info@filcom.de

FILCOM[®]
FILTRATION