

## Duplex Filter

### Pi 232

Nominal pressure 25 bar (360 psi), nominal size 800 and 1400

#### 1. Features

##### Duplex filter for gear boxes, lubrication and hydraulic systems

- Modular system
- Compact design
- Weight optimized design
- Minimal pressure drop through optimal flow design
- Flange connections, DIN DN 80, SAE 3"
- Visual/electrical maintenance indicator
- Drain on dirt and clean side
- Beta rated elements according to ISO 16889 multipass test
- Defined cleanliness classes according to ISO 4406/1999
- Elements with high differential pressure stability and dirt holding capacity
- Version according to DIN 24550 also deliverable
- Quality filters, easy to service
- Worldwide sales and service



## 2. Flow rate/pressure drop curve complete filter

190 mm<sup>2</sup>/s  
33 mm<sup>2</sup>/s

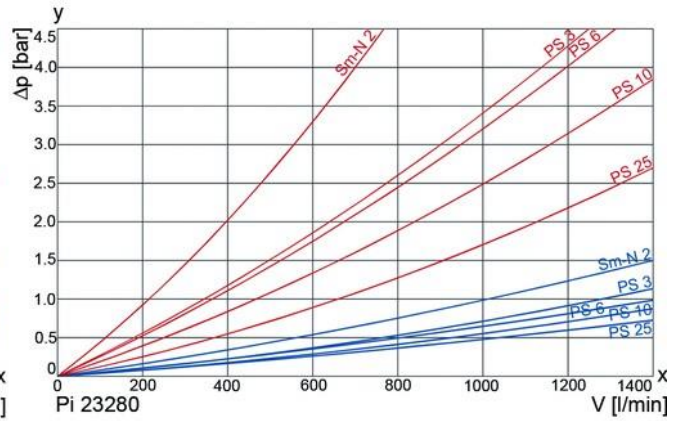
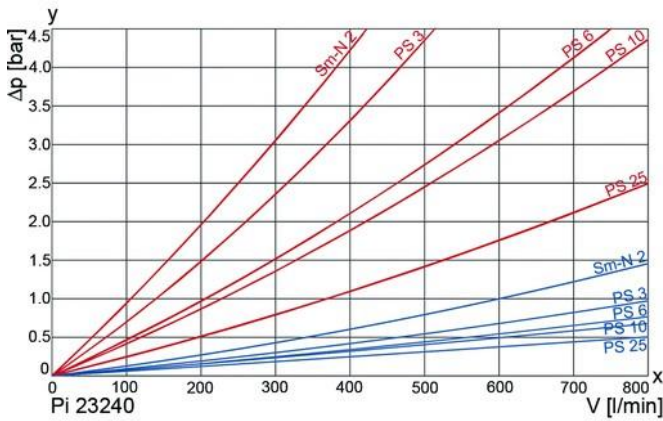

y = differential pressure  $\Delta p$  [bar]

x = flow rate V [l/min]

## 3. Separation grade characteristics

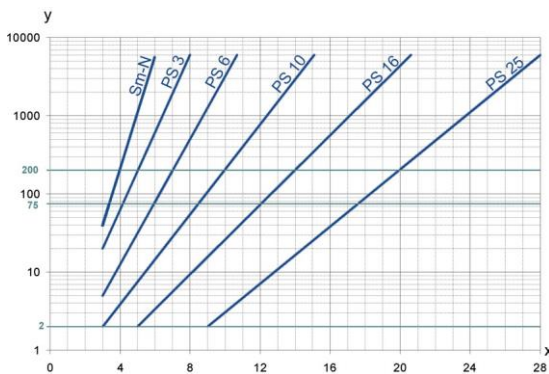

y = beta-value

x = particle size [ $\mu\text{m}$ ]

determined by multipass tests (ISO 16889)

calibration according to ISO 11171 (NIST)

## 4. Filter performance data

tested according to ISO 16889 (multipass test)

PS elements with

max.  $\Delta p$  20 bar

PS 3  $\beta_{5(C)} \geq 200$

PS 6  $\beta_{7(C)} \geq 200$

PS 10  $\beta_{10(C)} \geq 200$

PS 25  $\beta_{20(C)} \geq 200$

values guaranteed up to

10 bar differential pressure

## 5. Quality assurance

Filtration Group filters and filter elements are produced according to the following international standards:

Norm	Designation
DIN ISO 2941	Hydraulic fluid power filter elements; verification of collapse/burst resistance
DIN ISO 2942	Hydraulic fluid power filter elements, verification of fabrication integrity
DIN ISO 2943	Hydraulic fluid power filter elements, verification of material compatibility with fluids
DIN ISO 3723	Hydraulic fluid power filter elements, methods for end load test
DIN ISO 3724	Hydraulic fluid power filter elements, verification of flow fatigue characteristics
ISO 3968	Hydraulic fluid power filters; evaluation of pressure drop versus flow characteristics
ISO 10771.1	Fatigue pressure testing of metal containing envelopes in hydraulic fluid applications
ISO 16889	Hydraulic fluid power filters; multipass method for evaluation filtration performance of a filter element

## 6. Symbols

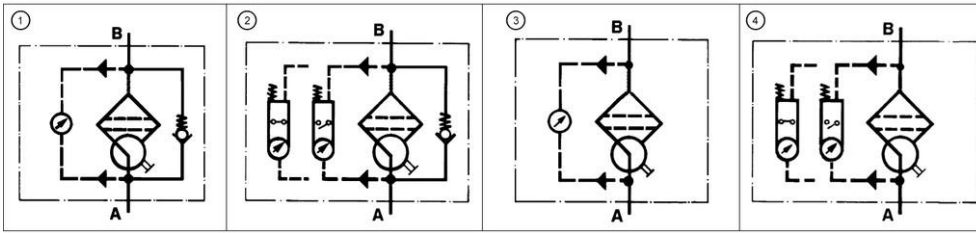

## 7. Order numbers

Example for ordering filters:

1. Housing design	2. 2x Filter element
V = 800 l/min and visual/electrical maintenance indicator Type: Pi 23240-069 Order number: 70554948	PS 25 Type: 852014 PS 25 Order number: 76321663

### 7.1 Housing design

Nominal size NG [l/min]	Order number	Type	①	②	③	④
			with bypass valve and visual indicator	with bypass valve and electrical indicator	with visual indicator	with electrical indicator
800	70554951	Pi 23240-057				
	70554950	Pi 23240-058				
	70554949	Pi 23240-068				
	70554948	Pi 23240-069				
1400	70554947	Pi 23280-057				
	70554942	Pi 23280-058				
	70554945	Pi 23280-068				
	70554946	Pi 23280-069				

When filter with non bypass configuration is selected the collapse pressure must not be exceeded!

### 7.2 Filter elements for standard housing design\*

Nominal size NG [l/min]	Order number	Type	Filter material	max. $\Delta p$ [bar]	Filter surface [cm <sup>2</sup> ]
800	76136220	852014 Sm-N 2	Sm-N 2	20	18533
	76321830	852014 PS 3	PS 3		24830
	76321822	852014 PS 6	PS 6		24830
	76321814	852014 PS 10	PS 10		24830
	76321806	852014 PS 25	PS 25		24830
1400	76136212	852015 Sm-N 2	Sm-N 2	20	42275
	76321897	852015 PS 3	PS 3		57200
	76321889	852015 PS 6	PS 6		57200
	76321871	852015 PS 10	PS 10		57200
	76321863	852015 PS 25	PS 25		57200

\*other element types are available on request

## 8. Technical specifications

Design:	line mounting filter
Nominal pressure:	10 <sup>7</sup> load changes 25 bar (360 psi)
Test pressure:	33 bar (470 psi)
Temperature range:	-10 °C to +120 °C
survival temperature	-40 °C (other temperature ranges on request)
	minimum viscosity of the fluid: 10 mm <sup>2</sup> /s
Bypass setting:	$\Delta p$ 3.5 bar $\pm$ 10
Filter head material:	GAL
Filter housing material:	AL
Filter cover material:	GAL
Sealing material:	NBR
Maintenance indicator setting	$\Delta p$ 2.2 bar $\pm$ 10 %
Electrical data of maintenance indicator:	
Max. voltage:	250 V AC/200 V DC
Max. current:	1 A
Contact load:	70 W
Type of protection:	IP 65 in inserted and secured status
Contact:	normally open/closed
Cable sleeve:	M20x1.5

The switching function can be changed by turning the electric upper part by 180° (normally closed contact or normally open contact). The state on delivery is a normally closed contact. By inductivity in the direct current circuit the use of suitable protection circuit should be considered. Further maintenance indicator details and designs are available in the maintenance indicator data sheet.

We draw attention to the fact that all values indicated are average values which do not always occur in specific cases of application. Our products are continually being further developed. Values, dimensions and weights can change as a result of this. Our specialized department will be pleased to offer you advice.

We recommend you to contact us concerning applications of our filters in areas governed by the EU Directive 94/9 EC (ATEX 95). The standard version can be used for liquids based on mineral oil (corresponding to the fluids in Group 2 of Directive 97/23 EC Article 9). If you consider to use other fluids please contact us for additional support.

Subject to technical alteration without prior notice.

## 9. Dimensions

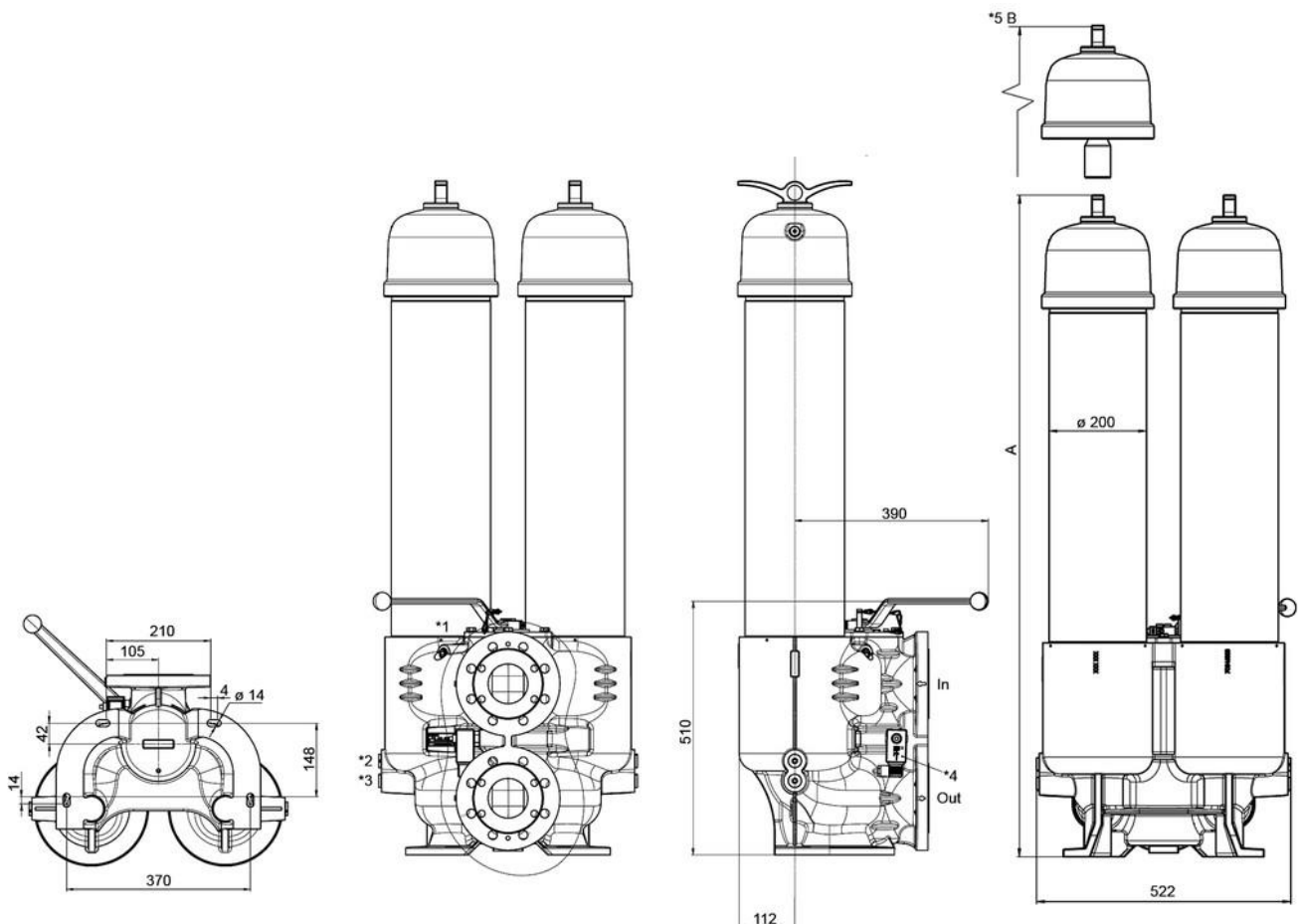

In	Inlet
Out	Outlet
*1	Pressure equalization screw
*2	Drain dirt side G $\frac{1}{2}$

*3	Drain clean side G $\frac{1}{2}$
*4	Maintenance indicator
*5	Clearance B

All dimensions in mm.

Type	Connection	A	B	Weight [kg]
Pi 23240	DN 80	805	500	80
Pi 23280	DN 80	1355	1000	90

## 10. Installation, operating and maintenance instructions

### 10.1 Filter installation

When installing the filter make sure that sufficient space is available to remove filter element and filter housing.

The maintenance indicator must be visible.

### 10.2 Connecting the electrical maintenance indicator

The electrical indicator is connected via a 2-pole appliance plug according to DIN EN 175301-803 with poles marked 1 and 2. The electrical section can be inverted to change from normally open to normally closed position or vice versa. The state on delivery is a normally closed contact.

### 10.3 When should the filter element be replaced?

- Filters equipped with visual and electrical maintenance indicator:  
During cold starts, the indicator may give a warning signal. Press the red button of the visual indicator once again only after operating temperature has been reached. If the red button immediately pops up again and/or the electrical signal has not switched off after reaching operating temperature the filter element must be replaced after the end of the shift.
- Filters without maintenance indicator:  
The filter element should be replaced after the trial run or flushing of the system. Afterwards follow instructions of the manufacturer.
- Please always ensure that you have original Filtration Group spare elements in stock: disposable elements (PS, Sm-N) cannot be cleaned.

### 10.4 Element replacement

**Note:** Elements may only be replaced by people who are familiar with the function of the filter. When replacing elements, appropriate safety clothing (protective goggles, gloves, safety shoes) must be worn.

**Note:** The maintenance indicator monitors the filter side in operation, which is identified by the position of the switching lever catch. The change-over transfer valve must be switched prior filter servicing. Now the signal of the maintenance indicators cancelled and the red button can be repressed again.

- Operate pressure equalizing screw. Swivel switching lever. Place through or drip pan underneath to collect leaving oil. Close pressure equalization screw.
- Loosen vent screw of the filter side not in use by 2-3 turns.
- Remove drain plug in housing bottom and drain oil.
- Unscrew filter cover counter-clockwise.  
**Warning: The shift lever may not, from now until the screwing back in of the filter housing (7.), be activated under any circumstances!**
- Lift out filter element.
- Check seal on filter cover. We recommend replacement in any case.
- Make sure that the order number on the spare element corresponds to the order number of the filter name-plate. Remove the element packaging and put the element with the o-Ring side down into the housing.
- Push the element carefully over the spigot and tight cover with the hand-tight.
- Tighten drain plug housing bottom.
- To refill the filter chamber, operate only the pressure equalizing screw. Tighten the screw when fluid emerges bubble-free from the drain.
- Tight vent screw. Check for leakage by actuating the equalizing screw again.

## 11. Spare parts list

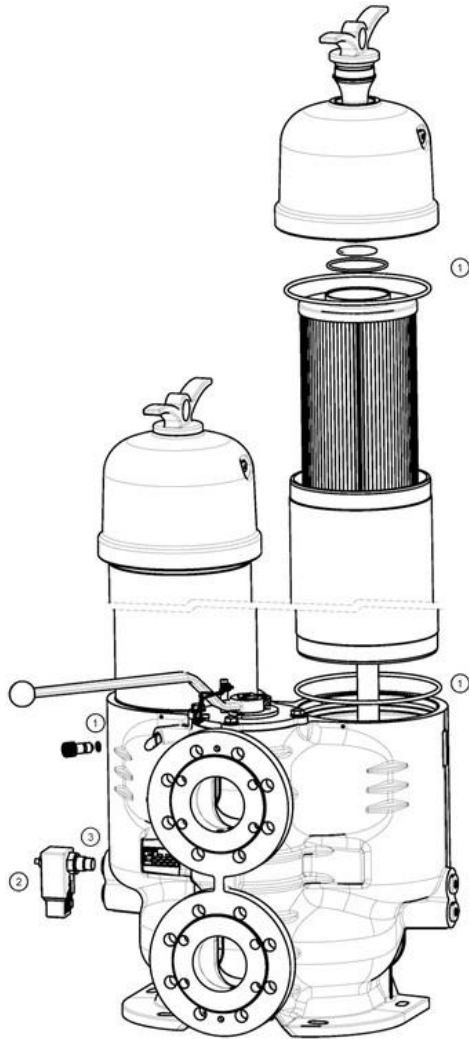

Order numbers for spare parts		
Position	Type	Order number
①	Seal kit for housing	
	NBR	70566903
	FPM	70566904
	EPDM	70566905
②	Maintenance indicator	
	Visual PiS 3098/2,2	77669971
	Visual/electrical PiS 3097/2,2	77669948
	Electrical upper section only	77536550
③	Seal kit for maintenance indicator	
	NBR	77760309
	FPM	77760317
	EPDM	77760325

### Your Contact

FILCOM GmbH  
Schönbuchstr. 1  
D-73760 Ostfildern

Phone: +49 (0) 711-4413322-0  
Fax: +49 (0) 711-4413322-22  
Mail: [info@filcom.de](mailto:info@filcom.de)

[www.filcom.de](http://www.filcom.de)

**FILCOM**<sup>®</sup>  
FILTRATION