

Duplex Filter Pi 251

Nominal pressure 16 bar, nominal size 2000 l/min

1. Summary

High performance filters for modern hydraulic, lubrication and fuel systems

- Compact design
- Minimal pressure drop through optimal flow design
- Visual/electrical/electronic maintenance indicator
- Extensive range of accessories
- Quality filters, easy to service
- Equipped with highly efficient PS or MB filter elements
- Beta rated elements according to ISO 16889 multipass test
- Elements with high differential pressure stability and dirt holding capacity
- Worldwide distribution



2. Flow rate/pressure drop curve (for version Pi2510200A)

190 mm²/s
33 mm²/s

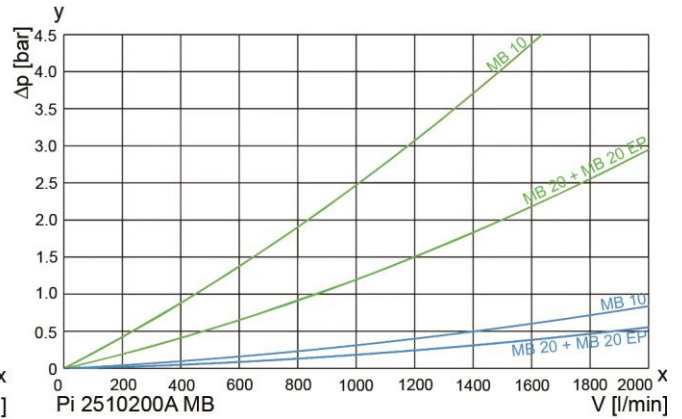
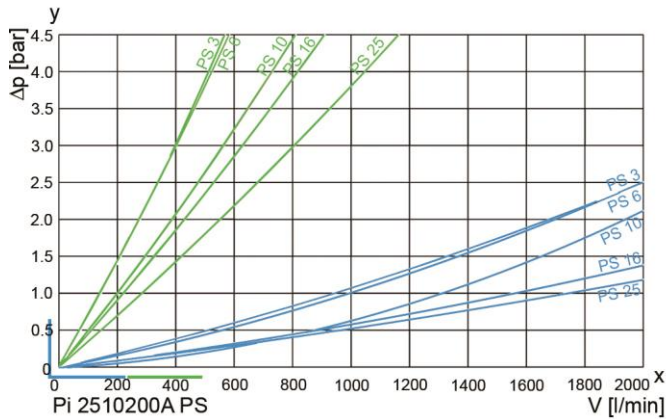

y = differential pressure Δp [bar]
x = flow rate V [l/min]
EP = e-protect version

3. Separation characteristics



y = beta value
x = particle size [μm]

determined from multipass measurements (ISO 16889)
calibration according to ISO 11171 (NIST)

4. Filter performance data

tested according to ISO 16889 (multipass test)
up to 10 bar differential pressure

PS elements with
Max. Δp 20 bar

PS 3 $\beta_{5(C)} \geq 200$
PS 6 $\beta_{7(C)} \geq 200$
PS 10 $\beta_{10(C)} \geq 200$
PS 16 $\beta_{15(C)} \geq 200$
PS 25 $\beta_{20(C)} \geq 200$

MB Elements with
Max. Δp 20 bar

MB 10 $\beta_{10(C)} \geq 200$
MB 20 $\beta_{20(C)} \geq 200$

5. Quality assurance

Filtration Group filters and filter elements are produced according to the following international standards:

Norm	Designation
DIN ISO 2941	Hydraulic fluid power filter elements; verification of collapse/burst resistance
DIN ISO 2942	Hydraulic fluid power filter elements; verification of fabrication integrity
DIN ISO 2943	Hydraulic fluid power filter elements; verification of material compatibility with fluids
DIN ISO 3723	Hydraulic fluid power filter elements; method for end load test
DIN ISO 3724	Hydraulic fluid power filter elements; verification of flow fatigue characteristics
ISO 3968	Hydraulic fluid power filters evaluation of pressure drop versus flow characteristics
ISO 10771.1	Fatigue pressure testing of metal containing envelopes in hydraulic fluid applications
ISO 16889	Hydraulic fluid power filters; multipass method for evaluation filtration performance of a filter element

6. Symbols

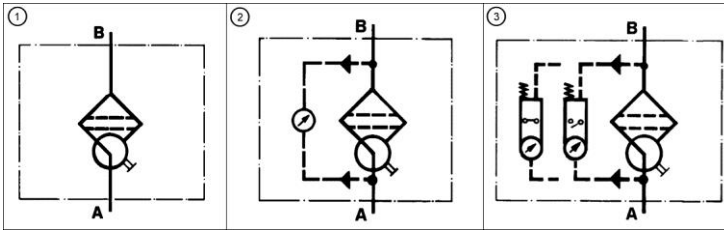

7. Type number key and order numbers

7.1 Type number key housing

Type

Pi 251 Duplex Filter

Nominal size

0200 NG 2000

Element length

A Short (standard)

B Long

Connection

2 DIN flange

3 ANSI flange

Nominal width

I DN 100/4"

J DN 125/5"

K DN 150/6"

Nominal pressure

2 16 bar

Switch

D Double disc valve

Seal material

F FPM (standard)

N NBR

Housing code

060 no options

118 with visual indicator

119 with visual/electrical indicator

Special equipment

31 Inspection certificate 3.1 acc. to DIN EN 10204

A Cover lifting tool

M Magnet

Paintwork

see type number key 7.2

Pi 251 0200 A/ 2 K/ 2 D/ F -119/ 31 Example for ordering

other types on request

7.2 Type number key paint (extract)

Primer

A	RAL 5007 approx. 80 µm ¹
B	RAL 5007 approx. 80 µm ²
C	RAL 7035 approx. 80 µm ¹
D	RAL 7035 approx. 80 µm ²
e	RAL 5007 min. 60 µm (standard)
F	RAL 5007 min. 100 µm
G	RAL 7035 min. 60 µm ³
H	RAL 9010 min. 60 µm ⁴
I	RAL 9010 min. 100 µm ³
J	RAL 7035 min. 60 µm
K	RAL 9010 min. 60 µm ³
L	RAL 7035 min. 80 µm ⁴

Intermediate layers (1 - 2 layers)

A	min. 120 µm (1 layer)
B	min. 160 µm (1 layer)
Y	without

Topcoat (layer thickness)

AL	min. 60 µm RAL 7030 silk matt
BC	min. 80 µm RAL 7001 silk matt
Q	min. 60 µm
ZZ	without

¹ preservation A

² preservation B

³ C3 coating according to ISO 12944

⁴ C4/C5 coating according to ISO 12944

other colors on request

Example for ordering filter:

1. Filter housing	2. Filter element
V = 2000 l/min, DIN DN 150 connection, nominal pressure 16 bar, double-disc switching, FPM seal and visual/electrical service indicator, with acceptance certificate 3.1 Type designation: Pi2510200A/2K/2D/F-119/31 Order number: on request	PS 10 Type designation: Pi 23200 AN PS 10 Order number: 70561158

7.3 Housing design

Nominal size NG [l/min]	Type	Number of elements each filter side
2000	see type code	1

7.4 Filter elements*

Nominal size NG [l/min]	Order number	Type	Filter media	max. Δp [bar]	Filter surface [cm ²]
2000	70561113	Pi 21200 AN PS 3	PS 3	20	40140
	70561152	Pi 22200 AN PS 6	PS 6		40140
	70561158	Pi 23200 AN PS 10	PS 10		40140
	70561161	Pi 24200 AN PS 16	PS 16		40140
	70561163	Pi 25200 AN PS 25	PS 25		40140
2000	72413295	Pi 41200 MB 10	MB 10	20	43708
	72351312	Pi 41200 MB 20	MB 20		43708
	70597037	Pi 41200 MB 20 EP*	MB 20 EP		43708

* e-protect version

8. Technical specifications

Design type:	Duplex Filter
Nominal pressure:	16 bar
Test pressure:	23.4 bar
Temperature range:	-10 ° C up to +120 ° C (other temperature ranges on request)
Filter housing material:	welded steel
Double disc valve material:	EN-GJS-400
Sealing material:	FPM/NBR/C4400
Maintenance indicator setting:	Δp 1.25 bar \pm 10 %
Electrical data of maintenance indicator:	
Maximum voltage:	250 V AC / 200 V DC
Maximum current:	1 A
Contact load:	70 W
Type of protection:	IP 65 in inserted and secured status
Contact type:	normally open/closed
Cable connection:	M20x1.5

The switching function can be changed by turning the electric upper part by 180° (normally closed contact or normally open contact). The state on delivery is a normally closed contact. By inductivity in the direct current circuit the use of suitable protection circuit should be considered. Further maintenance indicator details and designs are available in the maintenance indicator data sheet.

We draw attention to the fact that all values indicated are average values which do not always occur in specific cases of application. Our products are continually being further developed. Values, dimensions and weights can change as a result of this. Our specialized department will be pleased to offer you advice.

We recommend you to contact us concerning applications of our filters in areas governed by the EU Directive 94/9 EC (ATEX 95). The standard version can be used for liquids based on mineral oil (corresponding to the fluids in Group 2 of Directive 97/23 EC Article 9). If you consider to use other fluids please contact us for additional support.

Subject to technical alteration without prior notice.

9. Dimensions

Pi25102000A

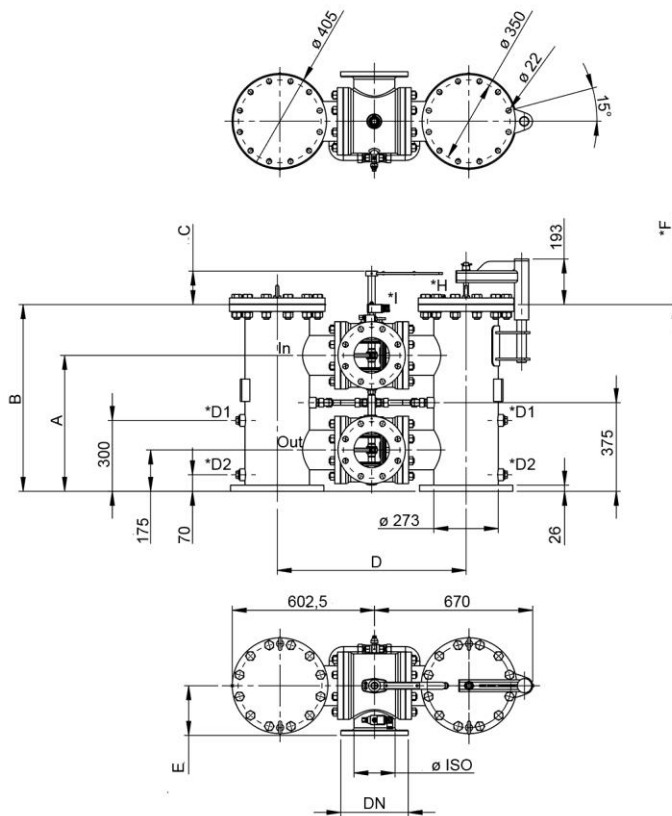

Pi25102000B

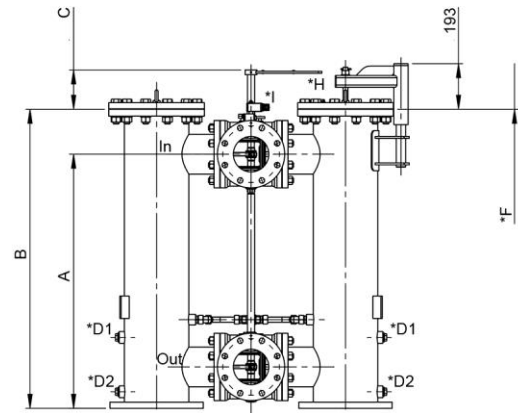

In Inlet
 Out Outlet
 *F Clearance
 *D1 Drain dirt side G1

*D2 Drain clean side G1
 *H Venting G $\frac{1}{2}$
 *I Connection maintenance indicator G $\frac{1}{4}$

Type	Cover lifting tool	Connections		A	B	C	D	e	*F	Wt. [kg]	Full]
		DN	\varnothing ISO								
Pi2510200A/2I/2D/ ... 31	-	100	114.3	575	790	142	739	180	500	380	43
Pi2510200A/2I/2D/ ... 31A	x										
Pi2510200A/2J/2D/ ... 31	-	125	139.7								
Pi2510200A/2J/2D/ ... 31A	x										
Pi2510200A/2K2D/ ... 31	-	150	168.3								
Pi2510200A/2K2D/ ... 31A	x										
Pi2510200B/2I/2D/ ... 31	-	100	114.3	1075	1075	167	739	180	1000	440	70
Pi2510200B/2I/2D/ ... 31A	x										
Pi2510200B/2J/2D/ ... 31	-	125	139.7								
Pi2510200B/2J/2D/ ... 31A	x										
Pi2510200B/2K2D/ ... 31	-	150	168.3								
Pi2510200B/2K2D/ ... 31A	x										

10. Installation, operating and maintenance instructions

see instruction manual

11. Spare parts and accessories lists

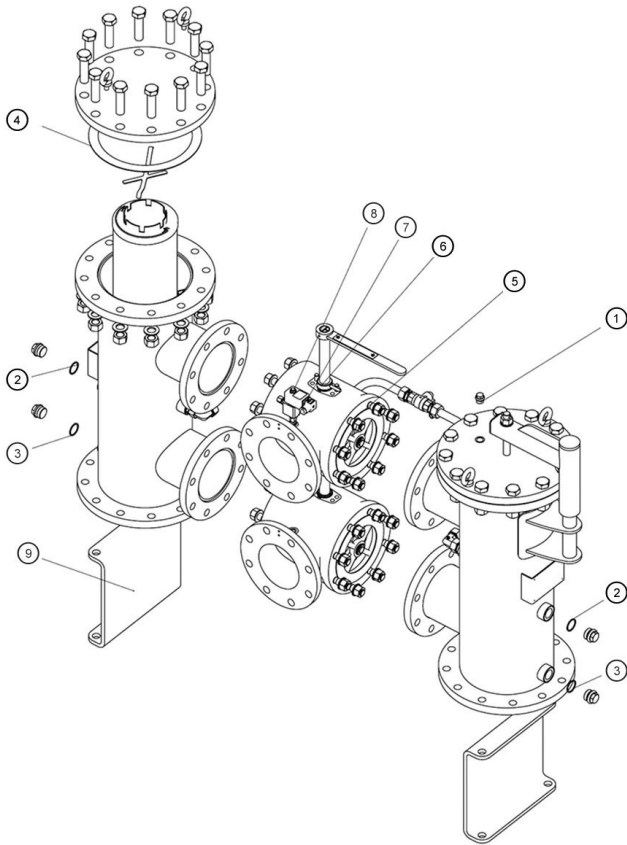

Order numbers for spare parts and accessories		
Position	Description	Order number
①-④	Seal kit for element change (per side)	
	D-set Pi2500200 / 2K / 2D ECO C4400	72472092
⑤	Seal kit changeover unit	
	DN 100	70601940
	DN 125	70605144
⑥	Bushing changeover unit	
	DN 100	70601942
	DN 125	70605150
⑦	Seal kit for maintenance indicator	
	NBR	77760309
	FPM	77760317
⑧	maintenance indicator	
	Optical PiS 3098 / 1.25	77809080
	Electric PiS 3097 / 1.25	70328693
⑨	Only electric shell	77536550
	optional accessories	on request

Your Contact

FILCOM GmbH
Schönbuchstr. 1
D-73760 Ostfildern

Phone: +49 (0) 711-4413322-0
Fax: +49 (0) 711-4413322-22
Mail: info@filcom.de

www.filcom.de

FILCOM[®]
FILTRATION