

High Pressure Filter Pi 410

Nominal pressure 315 bar (4480 psi), nominal size 20-63

1. Features

High performance filters for modern hydraulic systems

- Provided for valve block installation
- Modular system
- Compact design
- Minimal pressure drop through optimal flow design
- Visual/electrical/electronic maintenance indicator
- Connections according DIN 24340
- Quality filters, easy to service
- Equipped with highly efficient glass fibre PS filter elements
- Nominal sizes 40 and 63 equipped with filter elements according to DIN 24550
- Beta rated elements according to ISO 16889 multipass test
- Elements with high differential pressure stability and dirt holding capacity
- Worldwide distribution



2. Flow rate/pressure drop curve complete filter

190 mm²/s
33 mm²/s

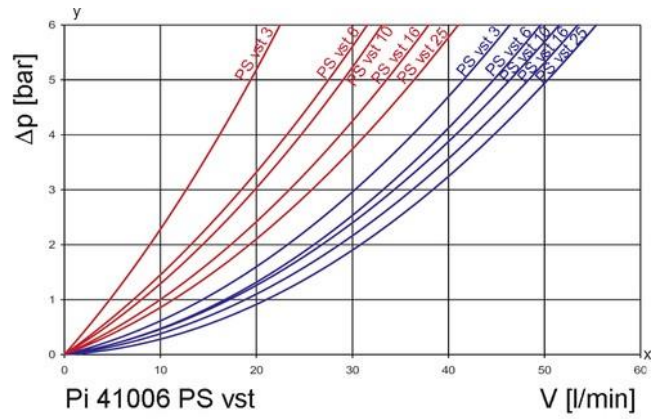
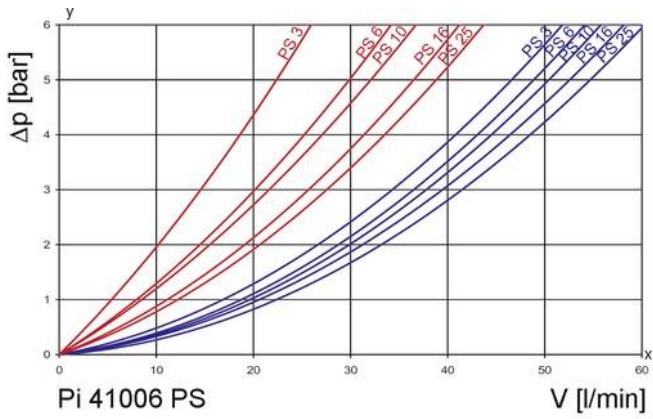
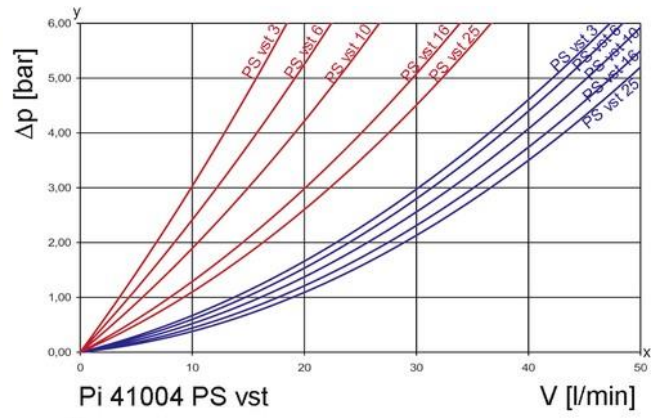
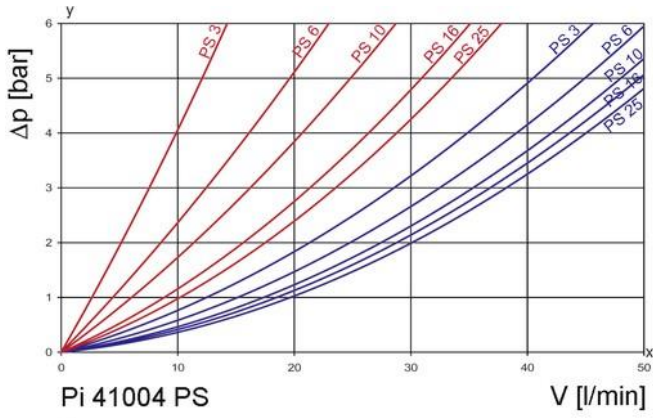
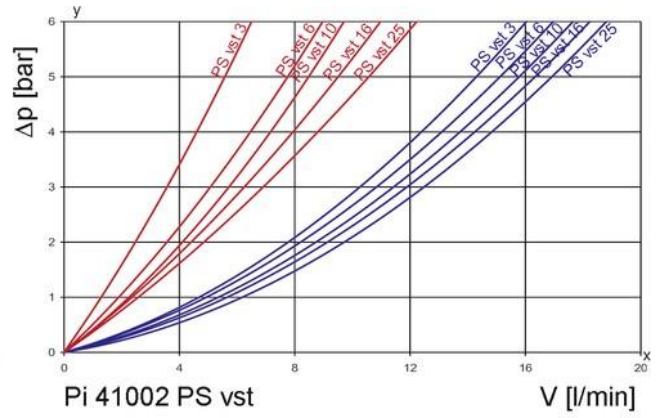
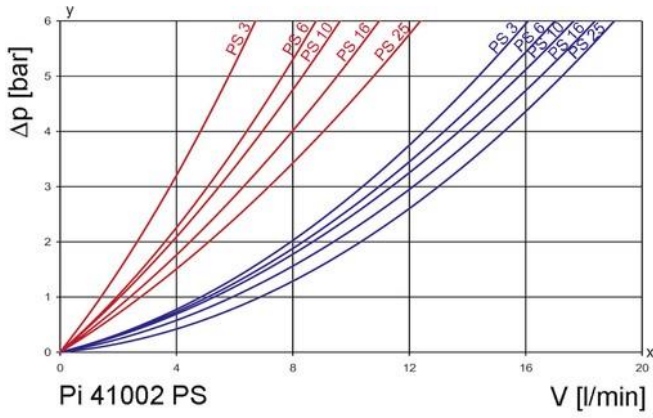

y = differential pressure Δp [bar]
x = flow rate V [l/min]

3. Separation grade characteristics

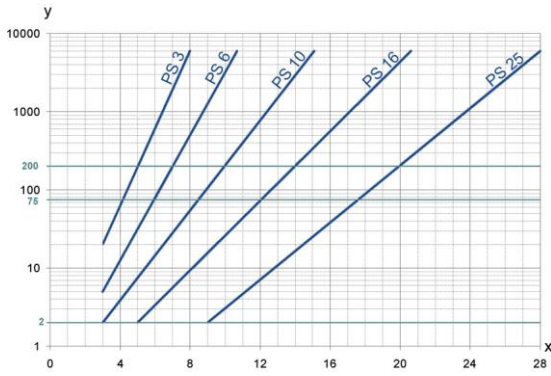

y = beta -value
x = particle size [μm]

determined by multipass tests (ISO 16889)
calibration according to ISO 11171 (NIST)

5. Quality assurance

Filtration Group filters and filter elements are produced according to the following international standards:

Norm	Designation
DIN ISO 2941	Hydraulic fluid power filter elements; verification of collapse/burst resistance
DIN ISO 2942	Hydraulic fluid power filter elements; verification of fabrication integrity
DIN ISO 2943	Hydraulic fluid power filter elements; verification of material compatibility with fluids
DIN ISO 3723	Hydraulic fluid power filter elements; method for end load test
DIN ISO 3724	Hydraulic fluid power filter elements; verification of flow fatigue characteristics
ISO 3968	Hydraulic fluid power filters; evaluation of pressure drop versus flow characteristics
ISO 10771.1	Fatigue pressure testing of metal containing envelopes in hydraulic fluid applications
ISO 16889	Hydraulic fluid power filters; multipass method for evaluation filtration performance of a filter element

6. Symbols

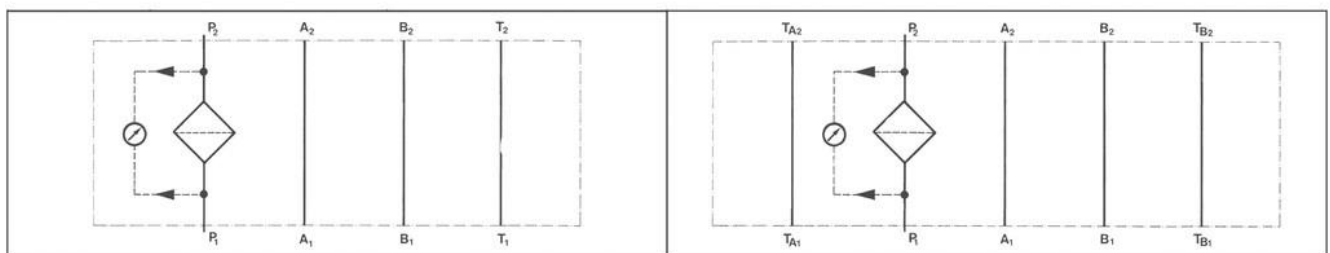
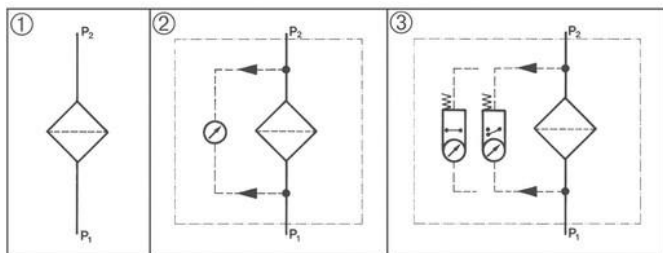

NG 20

NG 40-63

4. Filter performance data

tested according to ISO 16889 (multipass test)

PS elements with
max. Δp 20 bar

PS	3	$\beta_{5(C)} \geq 200$
PS	6	$\beta_{7(C)} \geq 200$
PS	10	$\beta_{10(C)} \geq 200$
PS	16	$\beta_{15(C)} \geq 200$
PS	25	$\beta_{20(C)} \geq 200$

values guaranteed up to
10 bar differential pressure

PS vst elements with
max. Δp 210 bar

PS vst	3	$\beta_{5(C)} \geq 200$
PS vst	6	$\beta_{7(C)} \geq 200$
PS vst	10	$\beta_{10(C)} \geq 200$
PS vst	16	$\beta_{15(C)} \geq 200$
PS vst	25	$\beta_{20(C)} \geq 200$

values guaranteed up to
20 bar differential pressure

7. Order numbers

Example for ordering filters:

1. Filter housing	2. Filter element
V = 40 l/min, visual/electrical indicator Type: Pi 41004-015/Order number: 77937600	PS 3 Type: Pi 21004 DN PS 3/Order number: 78260929

7.1 Housing design					
NG [l/min]	Order number	Type	with indicator cavity	with visual indicator	with electrical indicator
20	77937543	Pi 41002-046			
	77937550	Pi 41002-014			
	77937568	Pi 41002-015			
40	77937618	Pi 41004-046			
	77937592	Pi 41004-014			
	77937600	Pi 41004-015			
63	77937642	Pi 41006-046			
	77937626	Pi 41006-014			
	77937634	Pi 41006-015			

The collapse pressure of the element must not be exceeded.

7.2 Filter elements (a wider range of element types is available on request)						
NG [l/min]	Order number	Type	Filter material	max. Δp [bar]	Filter surface [cm ²]	
20	77685407	852 243 PS 3	PS 3	20	305	
	78216038	852 243 PS 6	PS 6		305	
	77740327	852 243 PS 10	PS 10		305	
	78216053	852 243 PS 16	PS 16		305	
	77685415	852 243 PS 25	PS 25		305	
	20	77685423	852 243 PS vst 3	PS vst 3	160	275
		78216046	852 243 PS vst 6	PS vst 6		275
		77685431	852 243 PS vst 10	PS vst 10		275
		78216061	852 243 PS vst 16	PS vst 16		275
		77685449	852 243 PS vst 25	PS vst 25		275
40	78260929	Pi 21004 DN PS 3	PS 3	20	475	
	77960859	Pi 22004 DN PS 6	PS 6		475	
	77925571	Pi 23004 DN PS 10	PS 10		475	
	78260937	Pi 24004 DN PS 16	PS 16		475	
	78260945	Pi 25004 DN PS 25	PS 25		475	
	40	78216079	Pi 71004 DN PS vst 3	PS vst 3	210	445
		77960156	Pi 72004 DN PS vst 6	PS vst 6		445
		77925654	Pi 73004 DN PS vst 10	PS vst 10		445
		78216087	Pi 74004 DN PS vst 16	PS vst 16		445
		78216095	Pi 75004 DN PS vst 25	PS vst 25		445
63	78260960	Pi 21006 DN PS 3	PS 3	20	835	
	77960867	Pi 22006 DN PS 6	PS 6		835	
	77925589	Pi 23006 DN PS 10	PS 10		835	
	78260978	Pi 24006 DN PS 16	PS 16		835	
	78260986	Pi 25006 DN PS 25	PS 25		835	
	63	78216137	Pi 71006 DN PS vst 3	PS vst 3	210	780
		77960149	Pi 72006 DN PS vst 6	PS vst 6		780
		77925662	Pi 73006 DN PS vst 10	PS vst 10		780
		78216145	Pi 74006 DN PS vst 16	PS vst 16		780
		78216152	Pi 75006 DN PS vst 25	PS vst 25		780

8. Technical specifications

Design:	installation in vertical interlink
Nominal pressure:	315 bar (4480 psi)
Test pressure:	410 bar (5830 psi)
Temperature range:	-10 °C to +120 °C (other temperature ranges on request)
Filter head material:	steel
Filter housing material:	steel
Sealing material:	NBR/PTFE
Maintenance indicator setting:	Δp 5 bar \pm 0.5 bar
Electrical data of maintenance indicator:	
Maximum voltage:	250 V AC/200 V DC
Maximum current on contact:	1 A
Inrush current:	70 W
Type of protection:	IP 65 in inserted and secured status
Contact:	normally open/closed
Cable sleeve:	M20x1.5

The switching function can be changed by turning the electric upper part by 180° (normally closed contact or normally open contact). The state on delivery is a normally closed contact. By inductivity in the direct current circuit the use of suitable protection circuit should be considered. Further maintenance indicator details and designs are available in the maintenance indicator data sheet.

We draw attention to the fact that all values indicated are average values which do not always occur in specific cases of application. Our products are continually being further developed. Values, dimensions and weights can change as a result of this. Our specialized department will be pleased to offer you advice.

We recommend to contact us concerning applications of our filters in areas governed by the EU Directive 94/9 EG (ATEX 95). The standard version can be used for liquids based on mineral oil (corresponding to the fluids in Group 2 of Directive 97/23 EG Article 9). If you consider to use other fluids please contact us for additional support.

Subject to technical alteration without prior notice.

9. Dimensions

Dimension	Pi 41002	Pi 41004	Pi 41006
A	241	235	295
B	48	70	70
C	3	5	5
D	2	8	8
E	SW 17	SW 27	SW 27
F	50	50	50
Master gauge for holes DIN 24340	A6	A10	A10
O-ring for connecting plate \varnothing	9.25x1.78	12x2	12x2
Weight [kg]	2.65	5.00	5.70

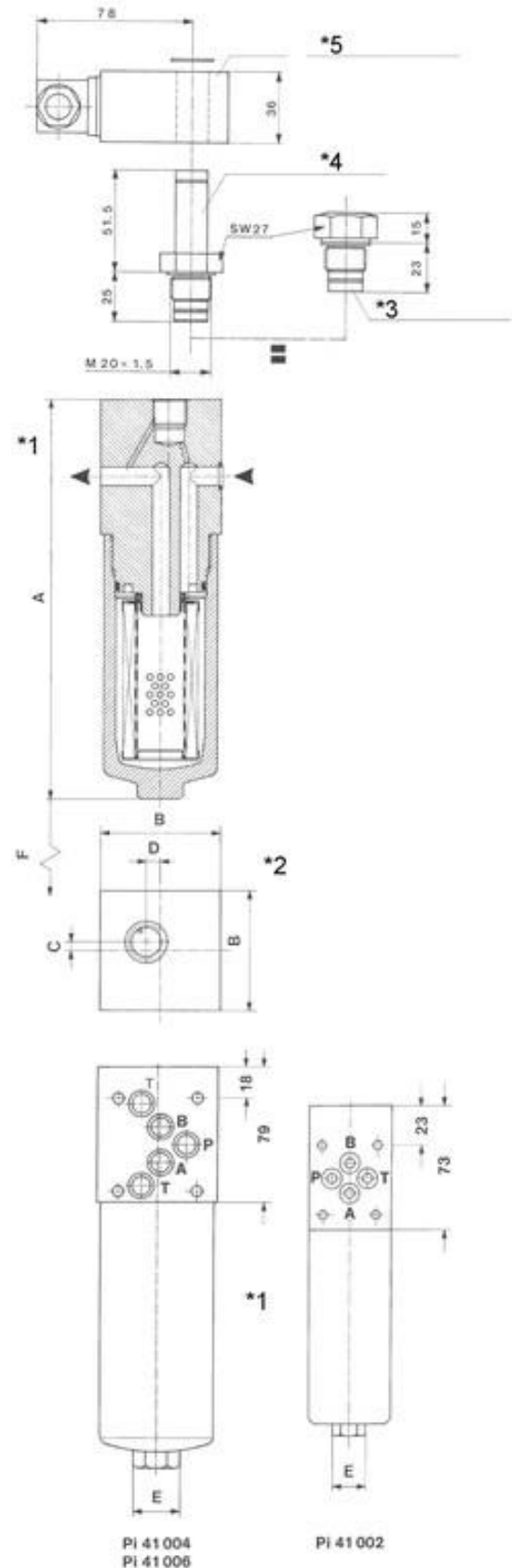

*1 View A

*2 View B

*3 Screw plug

*4 Visual maintenance indicator

*5 Electrical upper section for maintenance indicator

10. Installation, operating and maintenance instructions

10.1 Filter installation

When installing the filter make sure that sufficient space is available to remove filter element and filter bowl. Preferably the filter should be installed with the filter housing pointing downwards.

The maintenance indicator must be visible.

10.2 Connecting the electrical maintenance indicator

The electrical indicator is connected via a 2-pole appliance plug according to DIN EN 175301-803 with poles marked 1 and 2.

The electrical section can be inverted to change from normally open position to normally closed position or vice versa.

10.3 When should the filter element be replaced?

- Filters equipped with visual and electrical maintenance indicator:
During cold starts, the indicator may give a warning signal. Press the red button of the visual indicator once again only after operating temperature has been reached. If the red button immediately pops up again and/or the electrical signal has not switched off after reaching operating temperature, the filter element must be replaced after the end of the shift.
- Filters without maintenance indicator:
The filter element should be replaced after the trial run or flushing of the system. Afterwards follow instructions of the manufacturer.
- Please always ensure that you have original Filtration Group spare elements in stock: Disposable elements (PS) cannot be cleaned.

10.4 Element replacement

- Stop system and relieve filter from pressure.
- Unscrew the filter housing by turning counter-clockwise. Clean the housing using a suitable cleaning solvent.
- Remove the filter element by pulling down carefully.
- Check O-ring and spigot for damage. Replace, if necessary.
- Make sure that the order number on the spare element corresponds to the order number of the filter name-plate. To ensure no contamination occurs during the exchange of the element first open the plastic bag and push the element over the spigot in the filter head. Now remove plastic bag.
- Lightly lubricate the threads of the filter housing a little bit and screw into the filter head. Maximum tightening torque for NG 50 to 110 = 60 Nm, for NG 150 to 450 = 100 Nm.

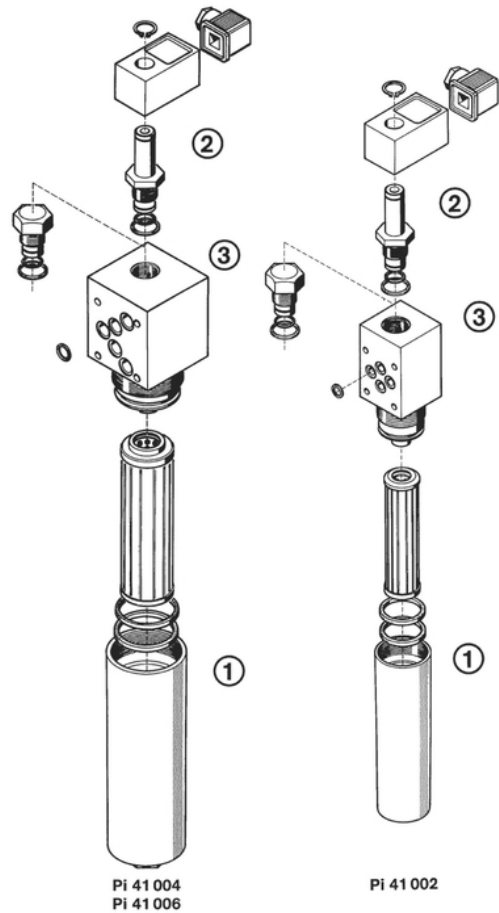

11. Spare parts list

Order numbers for spare parts		
Position	Type	Order number
①	Seal kit	
	Pi 41002	
	NBR	77996861
	FPM	77996879
	EPDM	77996887
	Pi 41004 - Pi 41006	
	NBR	77996895
	FPM	77996903
	EPDM	77996911
②	Maintenance indicator	
	Visual PiS 3093/5	77669914
	Electrical PiS 3092/5	77669864
	Electrical upper section only	77536550
③	Seal kit for maintenance indicator	
	NBR	77760275
	FPM	77760283
	EPDM	77760291

Your Contact

FILCOM GmbH
Schönbuchstr. 1
D-73760 Ostfildern
www.filcom.de

Phone: +49 (0) 711-4413322-0
Fax: +49 (0) 711-4413322-22
Mail: info@filcom.de

FILCOM
FILTRATION