

High Pressure Filter

Pi 4220

Nominal pressure 400 bar (5690 psi), nominal size up to 400
optional with reverse flow valve

1. Features

High performance filters for modern hydraulic systems

- Modular system
- Compact design
- Minimal pressure drop through optimal flow design
- Visual/electrical/electronic maintenance indicator
- Threaded or flanged connections
- Quality filters, easy to service
- Inlet sideways, outlet sideways or at the top
- Equipped with highly efficient glass fibre PS filter elements
- Beta rated elements according to ISO 16889 multipass test
- Elements with high differential pressure stability and dirt holding capacity
- NPT- and SAE-connections on request
- Worldwide distribution



2. Flow rate/pressure drop curve (filter housing incl. element)

190 mm²/s
33 mm²/s

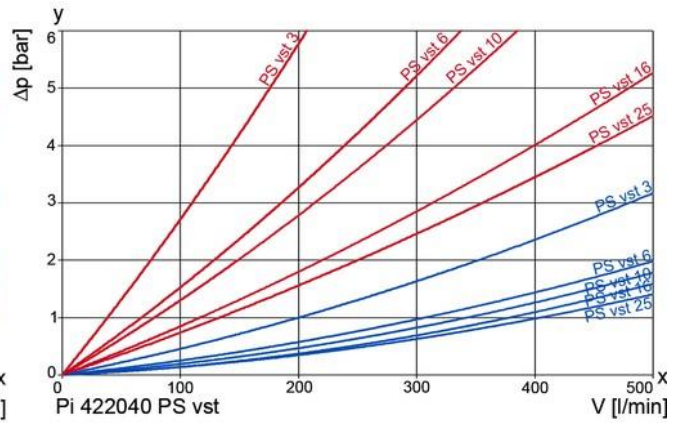
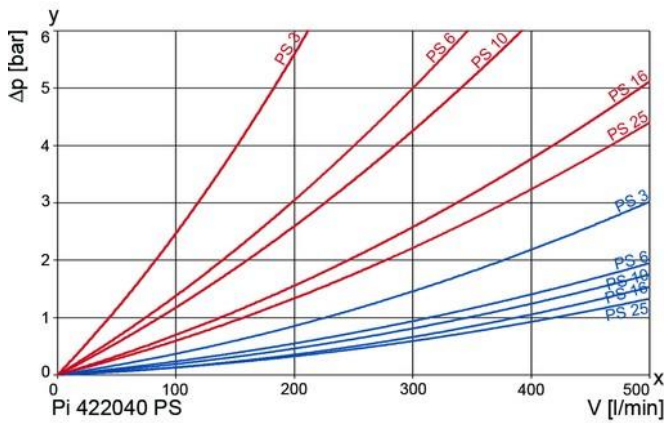
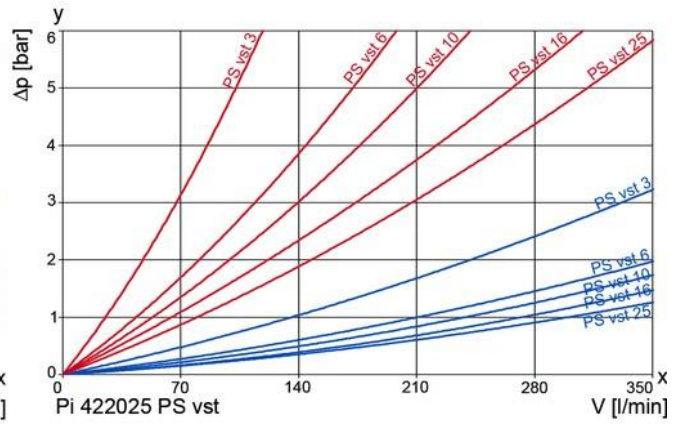
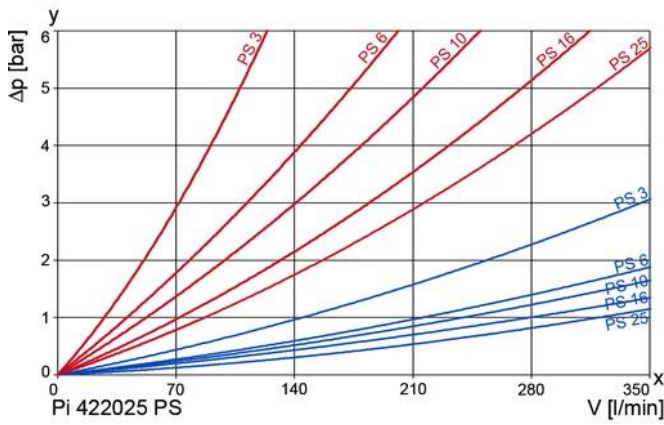
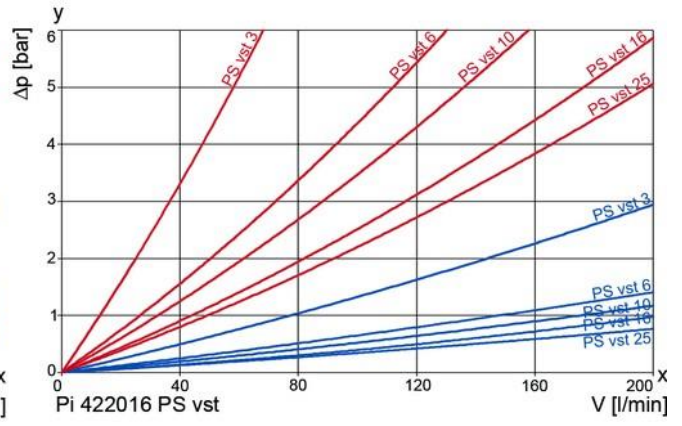
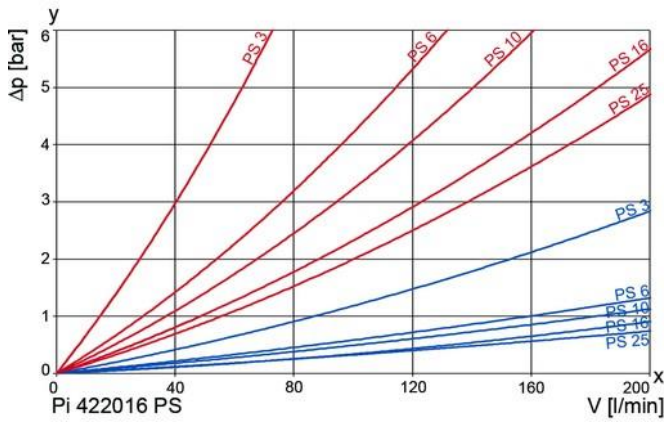

y = differential pressure Δp [bar]
x = flow rate V [l/min]

3. Separation grade characteristics

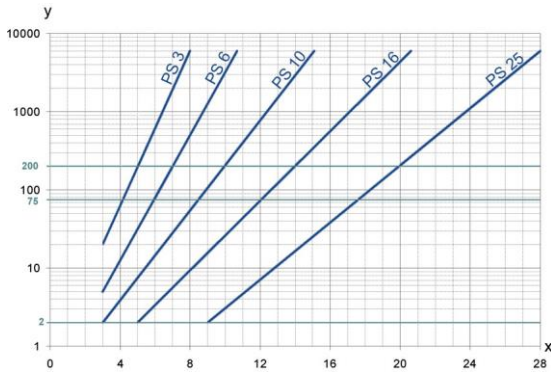

y = beta-value
x = particle-size [µm]

determined by multipass tests (ISO 16889)
calibration according to ISO 11171 (NIST)

4. Filter performance data

tested according to ISO 16889 (multipass test)

PS elements with
max. Δp 20 bar

PS	3	$\beta_{5(C)} \geq 200$
PS	6	$\beta_{7(C)} \geq 200$
PS	10	$\beta_{10(C)} \geq 200$
PS	16	$\beta_{15(C)} \geq 200$
PS	25	$\beta_{20(C)} \geq 200$

values guaranteed up to
10 bar differential pressure

PS vst elements with
max. Δp 210 bar

PS vst	3	$\beta_{5(C)} \geq 200$
PS vst	6	$\beta_{7(C)} \geq 200$
PS vst	10	$\beta_{10(C)} \geq 200$
PS vst	16	$\beta_{15(C)} \geq 200$
PS vst	25	$\beta_{20(C)} \geq 200$

values guaranteed up to
20 bar differential pressure

5. Quality assurance

Filtration Group filters and filter elements are produced according to the following international standards:

Norm	Designation
DIN ISO 2941	Hydraulic fluid power filter elements; verification of collapse/burst resistance
DIN ISO 2942	Hydraulic fluid power filter elements; verification of fabrication integrity
DIN ISO 2943	Hydraulic fluid power filter elements; verification of material compatibility with fluids
DIN ISO 3723	Hydraulic fluid power filter elements; method for end load test
DIN ISO 3724	Hydraulic fluid power filter elements; verification of flow fatigue characteristics
ISO 3968	Hydraulic fluid power-filters-evaluation of pressure drop versus flow characteristics
ISO 10771.1	Fatigue pressure testing of metal containing envelopes in hydraulic fluid applications
ISO 16889	Hydraulic fluid power filters-multipass method for evaluation filtration performance of a filter element

6. Symbols

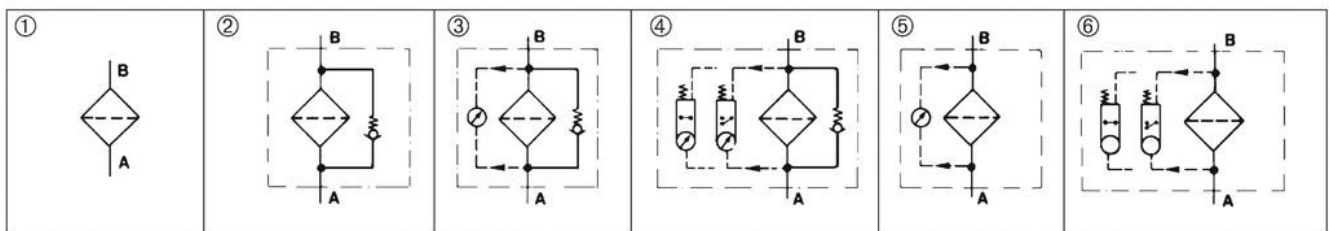

7. Type number key, housing design, order numbers

7.1 Type number key

Type	
Pi 4220	High pressure filter series
NG	
16	nominal size 160
25	nominal size 250
40	nominal size 400
Connection variant 1st position	
/1	inlet and outlet sideways
/2	inlet sideways, outlet at the top
Connection variant 2nd position	
1	G1½
2	flange SAE 1¼ (only for inlet sideways/outlet at the top version)
3	flange SAE 1½
4	G1¼ (only for inlet sideways/outlet at the top version)
Housing design	
-010	with hole for maintenance indicator
-011	with bypass valve and Bohrung für Wartungsanzeige
-012	with bypass valve and visual maintenance indicator
-013	with bypass valve and electrical maintenance indicator
-014	with visual maintenance indicator
-015	with electrical maintenance indicator
Pi 4220	25 /1 1 -011 ordering example

7.2 Housing design

Nominal size NG [l/min]	Type		①	②	③	④	⑤	⑥
	inlet sideways outlet sideways	inlet sideways outlet at the top	with hole for indicator	with bypass and hole for indicator	with bypass and visual indicator	with bypass and electrical indicator	with visual indicator	with electrical indicator
160	Pi 422016/1*-010	Pi 422016/2*-010						
	Pi 422016/1*-011	Pi 422016/2*-011						
	Pi 422016/1*-012	Pi 422016/2*-012						
	Pi 422016/1*-013	Pi 422016/2*-013						
	Pi 422016/1*-014	Pi 422016/2*-014						
	Pi 422016/1*-015	Pi 422016/2*-015						
250	Pi 422025/1*-010	Pi 422025/2*-010						
	Pi 422025/1*-011	Pi 422025/2*-011						
	Pi 422025/1*-012	Pi 422025/2*-012						
	Pi 422025/1*-013	Pi 422025/2*-013						
	Pi 422025/1*-014	Pi 422025/2*-014						
	Pi 422025/1*-015	Pi 422025/2*-015						
400	Pi 422040/1*-010	Pi 422040/2*-010						
	Pi 422040/1*-011	Pi 422040/2*-011						
	Pi 422040/1*-012	Pi 422040/2*-012						
	Pi 422040/1*-013	Pi 422040/2*-013						
	Pi 422040/1*-014	Pi 422040/2*-014						
	Pi 422040/1*-015	Pi 422040/2*-015						LEER

* Connection variants see type number key 2nd position

When filter with non bypass configuration is selected, the collapse pressure of the element must not be exceeded.

7.3 Filter elements					
Nominal size NG [l/min]	Order number	Typen designation	Filter material	max. Δp [bar]	Filter surface [cm ²]
160	78261034	Pi 21016 DN PS 3	PS 3	20	2530
	77960826	Pi 22016 DN PS 6	PS 6		2530
	77925605	Pi 23016 DN PS 10	PS 10		2530
	78261042	Pi 24016 DN PS 16	PS 16		2530
	78261059	Pi 25016 DN PS 25	PS 25		2530
	77940638	Pi 71016 DN PS vst 3	PS vst 3	210	1885
	77960123	Pi 72016 DN PS vst 6	PS vst 6		1885
	77925688	Pi 73016 DN PS vst 10	PS vst 10		1885
	78269797	Pi 74016 DN PS vst 16	PS vst 16		1885
	78216178	Pi 75016 DN PS vst 25	PS vst 25		1885
250	78227514	Pi 21025 DN PS 3	PS 3	20	4020
	77960834	Pi 22025 DN PS 6	PS 6		4020
	77925613	Pi 23025 DN PS 10	PS 10		4020
	78261075	Pi 24025 DN PS 16	PS 16		4020
	78261083	Pi 25025 DN PS 25	PS 25		4020
	77940646	Pi 71025 DN PS vst 3	PS vst 3	210	3090
	77960115	Pi 72025 DN PS vst 6	PS vst 6		3090
	77925696	Pi 73025 DN PS vst 10	PS vst 10		3090
	78269813	Pi 74025 DN PS vst 16	PS vst 16		3090
	78216186	Pi 75025 DN PS vst 25	PS vst 25		3090
400	78227522	Pi 21040 DN PS 3	PS 3	20	6770
	77960842	Pi 22040 DN PS 6	PS 6		6770
	77925621	Pi 23040 DN PS 10	PS 10		6770
	78261109	Pi 24040 DN PS 16	PS 16		6770
	78261117	Pi 25040 DN PS 25	PS 25		6770
	77940653	Pi 71040 DN PS vst 3	PSvst 3	210	5240
	77960107	Pi 72040 DN PS vst 6	PS vst 6		5240
	77930829	Pi 73040 DN PS vst 10	PS vst 10		5240
	78269821	Pi 74040 DN PS vst 16	PS vst 16		5240
	78260903	Pi 75040 DN PS vst 25	PS vst 25		5240

8. Technical specifications

Design:	in-line filter inlet sideways; outlet optional sideways or on top
Nominal pressure:	400 bar (5690 psi)
Test pressure:	520 bar (7400 psi)
Temperature range:	-10 °C to +120 °C (other temperature ranges on request)
Bypass setting:	Δp 7 bar \pm 10 %
Filter head material:	GGG
Filter housing material:	St
Sealing material:	NBR/PTFE
Maintenance indicator setting:	Δp 5 bar \pm 10 %
Electrical data of maintenance indicator:	
Maximum voltage:	250 V AC/200 V DC
Maximum current:	1 A
Contact load:	70 W
Type of protection:	IP 65 in inserted and secured status
Contact:	normally open/closed
Cable sleeve:	M20x1.5

The switching function can be changed by turning the electric upper part by 180° (normally closed contact or normally open contact). The state on delivery is a normally closed contact. By inductivity in the direct current circuit the use of suitable protection circuit should be considered. Further maintenance indicator details and designs are available in the maintenance indicator data sheet.

We draw attention to the fact that all values indicated are average values and not always occur in specific cases of application. Our products are continually being further developed. Values, dimensions and weights can change as a result of this. Our specialized department will be pleased to offer you advice.

We recommend to contact us concerning applications of our filters in areas governed by the EU Directive 94/9 EG (ATEX 95). The standard version can be used for liquids based on mineral oil (corresponding to the fluids in Group 2 of Directive 97/23 EG Article 9). If you consider to use other fluids please contact us for additional support.

Subject to technical alteration without prior notice.

9. Dimensions

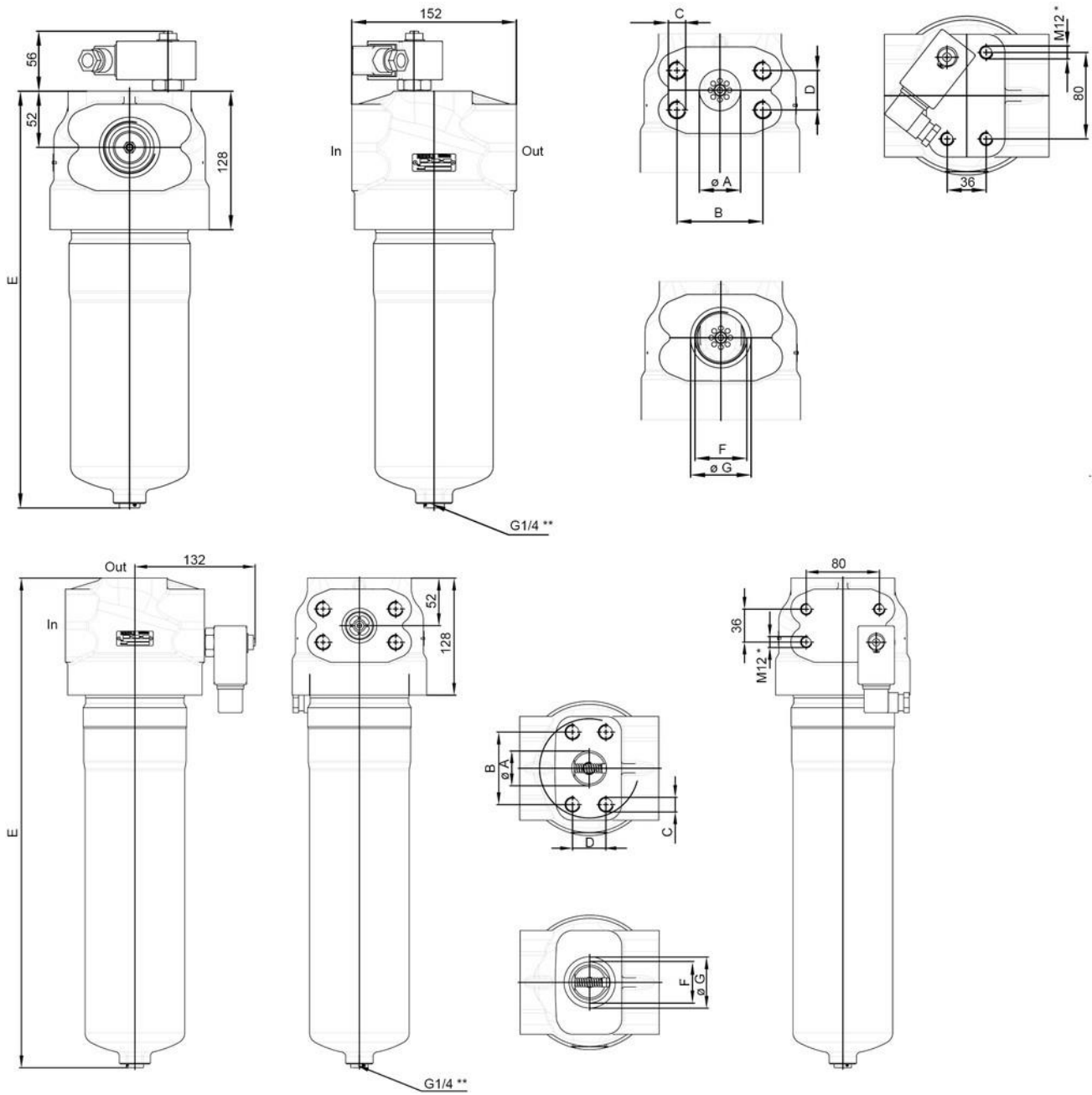

In = Inlet

Out = Outlet

* Thread depth 17 mm

** NG 160 without drain screw

All dimensions except "NG" in mm.

Type	NG	E
Pi 422016/...	150	292
Pi 422025/...	300	385
Pi 422040/...	450	535

All dimensions except "F" in mm.

Con- nection	ø A	B	C	D	F	ø G
G1¼ *	-	-	-	-	1¼"	56
G1½	-	-	-	-	1½"	56
SAE1¼ *	32	66,6	M12	31,8	-	-
SAE1½	38	79,3	M16	36,8	-	-

* only for inlet sideways/outlet at the top version

10. Execution with reverse flow valve

Filters are normally designed for single-direction flow only. Reverse flows result in destruction of the cartridge. Some applications can require the medium to flow through the filter in both directions, however. The Pi 4220 with a reverse flow valve can be used here. It allows medium flows in both directions, although it only filters in one. The liquid is not filtered in reverse mode. The reverse flow valve can be supplied with or without a bypass function.

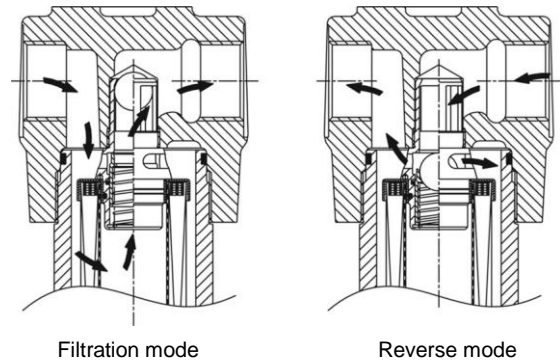

11. Installation, operating and maintenance instructions

11.1 Filter installation

When installing the filter make sure that sufficient space is available to remove filter element and filter housing. Preferably the filter should be installed with the filter housing pointing downwards.

The maintenance indicator must be visible.

11.2 Connecting the electrical maintenance indicator

The electrical indicator is connected via a 2-pole appliance plug according to DIN EN 175301-803 with poles marked 1 and 2. The electrical section can be inverted to change from normally open position to normally closed position or vice versa.

11.3 When should the filter element be replaced?

1. Filters equipped with visual and electrical maintenance indicator: During cold starts, the indicator may give a warning signal. Press the red button of the visual indicator once again only after operating temperature has been reached. If the red button immediately pops up again and/or the electrical signal has not switched off after reaching operating temperature, the filter element must be replaced after the end of the shift.
2. Filters without maintenance indicator: The filter element should be replaced after the trial run or flushing of the system. Afterwards follow instructions of the manufacturer.
3. Please always ensure that you have original Filtration Group spare elements in stock: Disposable elements (PS) cannot be cleaned.

11.4 Element replacement

1. Stop system and relieve filter from pressure.
2. Filter sizes 250 and 400: empty the filter housing by removing the drain plug.
3. Unscrew the filter housing by turning counter-clockwise. Clean the housing using a suitable cleaning solvent.
4. Remove element by pulling down carefully.
5. Check o-ring and spigot for damage. Replace, if necessary.
6. Make sure that the order number on the spare element corresponds to the order number of the filter name-plate. To ensure no contamination occurs during the exchange of the element first open the plastic bag and push the element over the spigot in the filter head. Now remove plastic bag.
7. Oil the threads of the filter housing a little bit and screw into the filter head. Maximum tightening torque for NG 160 to 400 = 100 Nm.
8. Check seals of vent drain plug - if necessary, please replace. Torque drain plug 30 Nm.

12. Spare parts list

Order numbers for spare parts		
Position	Type	Order number
① - ②	Seal kit	
	NBR	78383838
	FPM	78383846
	EPDM	78383853
③	Maintenance indicator	
	Visual PiS 3093/5	77669914
	Electrical PiS 3092/5	77669864
	Electrical upper section only	77536550
④	Seal kit for maintenance indicator	
	NBR	77760275
	FPM	77760283
	EPDM	77760291

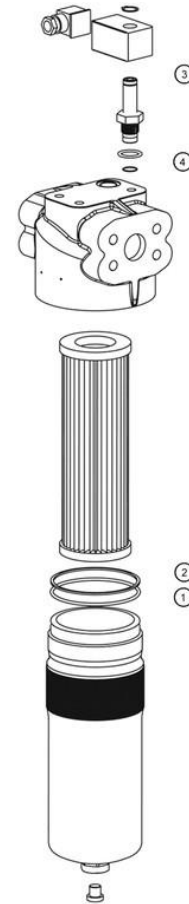

Your Contact

FILCOM GmbH
Schönbuchstr. 1
D-73760 Ostfildern

www.filcom.de

Phone: +49 (0) 711-4413322-0
Fax: +49 (0) 711-4413322-22
Mail: info@filcom.de

FILCOM[®]
FILTRATION