

## High Pressure Filter

### Pi 4230

Nominal pressure 315 bar (4570 psi), nominal size 160 to 400  
according DIN 24550

#### 1. Features

##### High performance filters for modern hydraulic systems

- Modular system
- Compact design
- Minimal pressure drop through optimal flow design
- Visual/electrical/electronic maintenance indicator
- Quality filters, easy to service
- Filter element removal upwards
- Equipped with highly efficient glass fibre PS filter elements
- Beta rated elements according to ISO 16889 multipass test
- Elements with high differential pressure stability and dirt holding capacity
- Worldwide distribution



## 2. Flow rate/pressure drop curve (filter housing incl. element)

190 mm<sup>2</sup>/s  
33 mm<sup>2</sup>/s

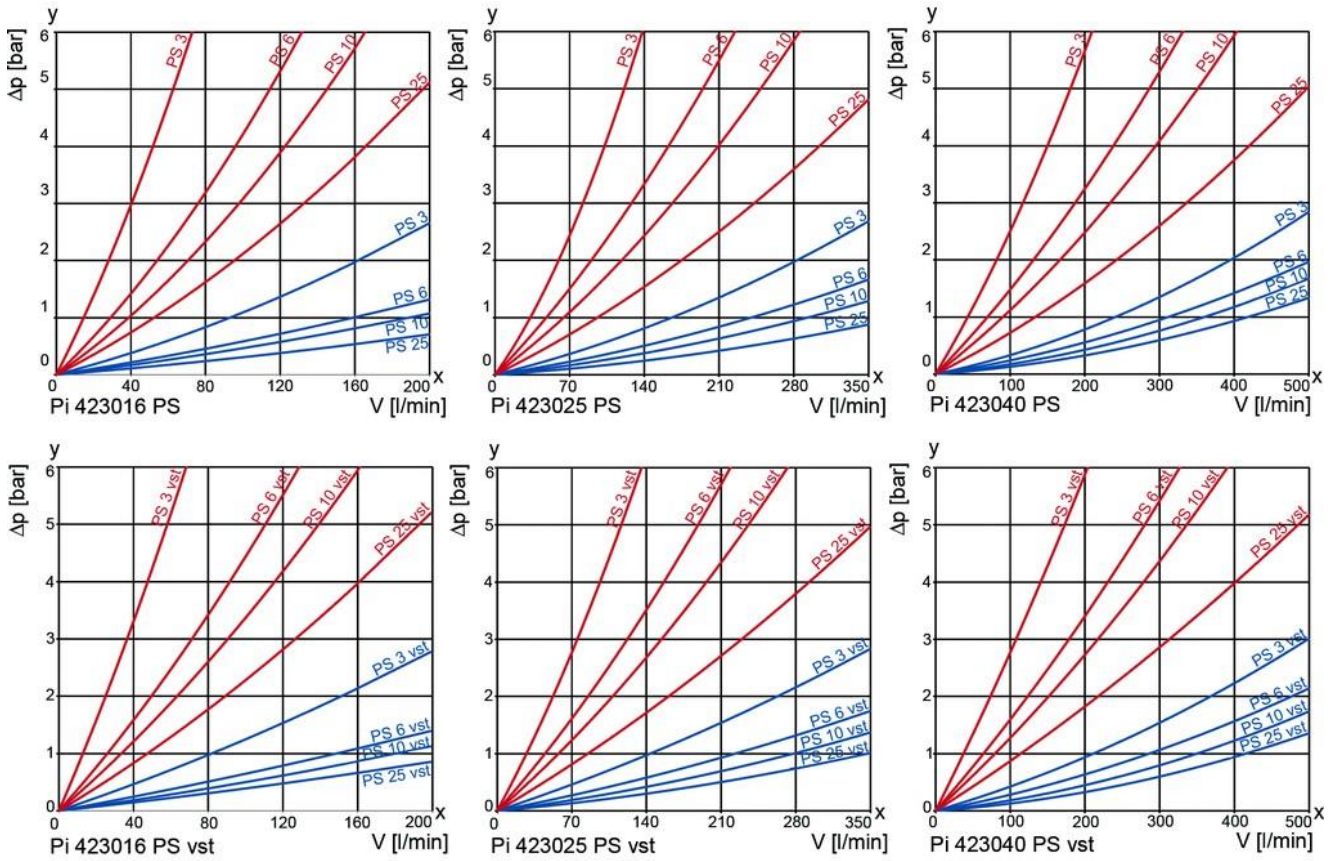

y = differential pressure  $\Delta p$  [bar]  
x = flow rate  $V$  [l/min]

### 3. Separation grade characteristics

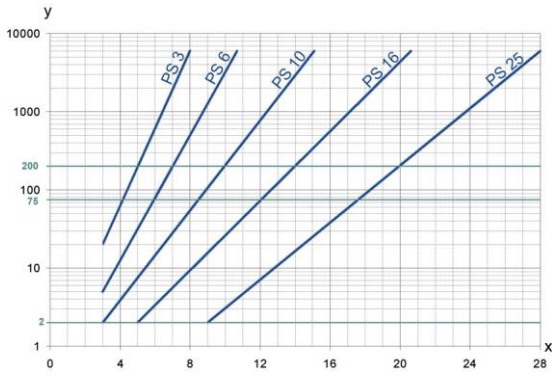

y = beta-value  
x = particle size [ $\mu\text{m}$ ]

determined by multipass tests (ISO 16889)  
calibration according to ISO 11171 (NIST)

### 5. Quality assurance

Filtration Group filters and filter elements are produced according to the following international standards:

Norm	Designation
DIN ISO 2941	Hydraulic fluid power filter elements; verification of collapse/burst resistance
DIN ISO 2942	Hydraulic fluid power filter elements; verification of fabrication integrity
DIN ISO 2943	Hydraulic fluid power filter elements; verification of material compatibility with fluids
DIN ISO 3723	Hydraulic fluid power filter elements; method for end load test
DIN ISO 3724	Hydraulic fluid power filter elements; verification of flow fatigue characteristics
ISO 3968	Hydraulic fluid power filters; evaluation of pressure drop versus flow characteristics
ISO 10771.1	Fatigue pressure testing of metal containing envelopes in hydraulic fluid applications
ISO 16889	Hydraulic fluid power filters; multipass method for evaluation filtration performance of a filter element

### 6. Symbols

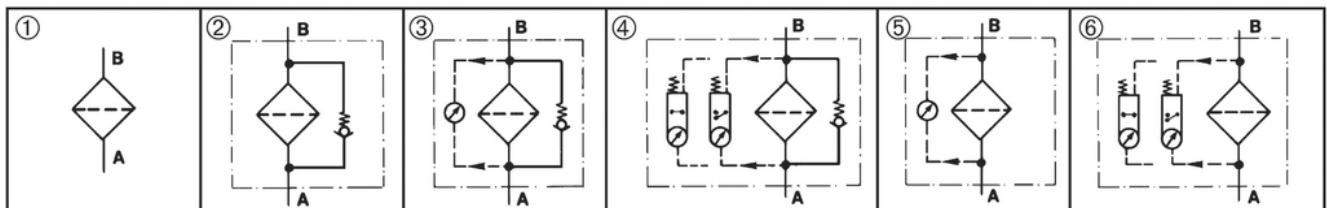

### 4. Filter performance data

tested according to ISO 16889 (multipass test)

PS elements with  
max.  $\Delta p$  20 bar

PS 3  $\beta_{5(C)} \geq 200$   
PS 6  $\beta_{7(C)} \geq 200$   
PS 10  $\beta_{10(C)} \geq 200$   
PS 25  $\beta_{20(C)} \geq 200$

values guaranteed up to  
10 bar differential pressure

PS vst elements with  
max.  $\Delta p$  210 bar

PS vst 3  $\beta_{5(C)} \geq 200$   
PS vst 6  $\beta_{7(C)} \geq 200$   
PS vst 10  $\beta_{10(C)} \geq 200$   
PS vst 25  $\beta_{20(C)} \geq 200$

values guaranteed up to  
20 bar differential pressure

## 7. Order numbers

Example for ordering filters:

1. Housing design	2. Filter elements
V = 250 l/min, electrical maintenance indicator Type: Pi 423025-015 Order number: 70382542	PS vst 3 Type: Pi 71025 DN PS vst 3 Order number: 77940646

7.1 Housing design										
Nominal size NG [l/min]	Order number thread version	Type thread version	Order number flange version	Type flange version	① with indicator cavity	② with bypass valve and indicator cavity	③ with bypass valve and visual indicator	④ with bypass valve and visual/electrical indicator	⑤ with visual indicator	⑥ with visual/electrical indicator
160	70382531	Pi 423016-010	70382566	Pi 423016-010 FL						
	70382532	Pi 423016-011	70382567	Pi 423016-011 FL						
	70382533	Pi 423016-012	70382568	Pi 423016-012 FL						
	70382534	Pi 423016-013	70382569	Pi 423016-013 FL						
	70382535	Pi 423016-014	70382570	Pi 423016-014 FL						
	70382536	Pi 423016-015	70382571	Pi 423016-015 FL						
250	70382537	Pi 423025-010	70382572	Pi 423025-010 FL						
	70382538	Pi 423025-011	70382573	Pi 423025-011 FL						
	70382539	Pi 423025-012	70382574	Pi 423025-012 FL						
	70382540	Pi 423025-013	70382575	Pi 423025-013 FL						
	70382541	Pi 423025-014	70382576	Pi 423025-014 FL						
	70382542	Pi 423025-015	70382577	Pi 423025-015 FL						
400	70382543	Pi 423040-010	70382578	Pi 423040-010 FL						
	70382544	Pi 423040-011	70382579	Pi 423040-011 FL						
	70382545	Pi 423040-012	70382580	Pi 423040-012 FL						
	70382546	Pi 423040-013	70382581	Pi 423040-013 FL						
	70382547	Pi 423040-014	70382582	Pi 423040-014 FL						
	70382548	Pi 423040-015	70382583	Pi 423040-015 FL						

When filter with non bypass configuration is selected, the collapse pressure of the element must not be exceeded.

## 7.2 Filter elements\*

Nominal size NG [l/min]	Order number	Type	Filter material	max. $\Delta p$ [bar]	Filter surface [cm <sup>2</sup> ]
160	78261034	Pi 21016 DN PS 3	PS 3	20	2530
	77960826	Pi 22016 DN PS 6	PS 6		2530
	77925605	Pi 23016 DN PS 10	PS 10		2530
	78261042	Pi 24016 DN PS 16	PS 16		2530
	78261059	Pi 25016 DN PS 25	PS 25		2530
	77940638	Pi 71016 DN PS vst 3	PS vst 3	210	1885
	77960123	Pi 72016 DN PS vst 6	PS vst 6		1885
	77925688	Pi 73016 DN PS vst 10	PS vst 10		1885
	78269797	Pi 74016 DN PS vst 16	PS vst 16		1885
	78216178	Pi 75016 DN PS vst 25	PS vst 25		1885
250	78227514	Pi 21025 DN PS 3	PS 3	20	4020
	77960834	Pi 22025 DN PS 6	PS 6		4020
	77925613	Pi 23025 DN PS 10	PS 10		4020
	78261075	Pi 24025 DN PS 16	PS 16		4020
	78261083	Pi 25025 DN PS 25	PS 25		4020
	77940646	Pi 71025 DN PS vst 3	PS vst 3	210	3090
	77960115	Pi 72025 DN PS vst 6	PS vst 6		3090
	77925696	Pi 73025 DN PS vst 10	PS vst 10		3090
	78269813	Pi 74025 DN PS vst 16	PS vst 16		3090
	78216186	Pi 75025 DN PS vst 25	PS vst 25		3090
400	78227522	Pi 21040 DN PS 3	PS 3	20	6770
	77960842	Pi 22040 DN PS 6	PS 6		6770
	77925621	Pi 23040 DN PS 10	PS 10		6770
	78261109	Pi 24040 DN PS 16	PS 16		6770
	78261117	Pi 25040 DN PS 25	PS 25		6770
	77940653	Pi 71040 DN PS vst 3	PS vst 3	210	5240
	77960107	Pi 72040 DN PS vst 6	PS vst 6		5240
	77930829	Pi 73040 DN PS vst 10	PS vst 10		5240
	78269821	Pi 74040 DN PS vst 16	PS vst 16		5240
	78260903	Pi 75040 DN PS vst 25	PS vst 25		5240

\* a wider range of element types is available on request

## 8. Technical specifications

Design:	in-line filter
Nominal pressure:	315 bar (4570 psi)
Test pressure:	410 bar (5940 psi)
Temperature range:	-10 °C to +120 °C (other temperature ranges on request)
Bypass setting:	$\Delta p$ 7 bar $\pm$ 10 %
Filter head material:	GGG
Filter housing material:	St
Sealing material:	NBR/PTFE/Cu
Maintenance indicator setting:	$\Delta p$ 5 bar $\pm$ 10 %
Electrical data of maintenance indicator:	
Maximum voltage:	250 V AC/200 V DC
Maximum current:	1 A
Contact load:	70 W
Type of protection:	IP 65 in inserted and secured status
Contact:	normally open/closed
Cable sleeve:	M20x1.5

The switching function can be changed by turning the electric upper part by 180° (normally closed contact or normally open contact). The state on delivery is a normally closed contact. By inductivity in the direct current circuit the use of suitable protection circuit should be considered. Further maintenance indicator details and designs are available in the maintenance indicator data sheet.

We draw attention to the fact that all values indicated are average values and not not always occur in specific cases of application. Our products are continually being further developed. Values, dimensions and weights can change as a result of this. Our specialized department will be pleased to offer you advice.

We recommend to contact us concerning applications of our filters in areas governed by the EU Directive 94/9 EG (ATEX 95). The standard version can be used for liquids based on mineral oil (corresponding to the fluids in Group 2 of Directive 97/23 EG Article 9). If you consider to use other fluids please contact us for additional support.

Subject to technical alteration without prior notice.

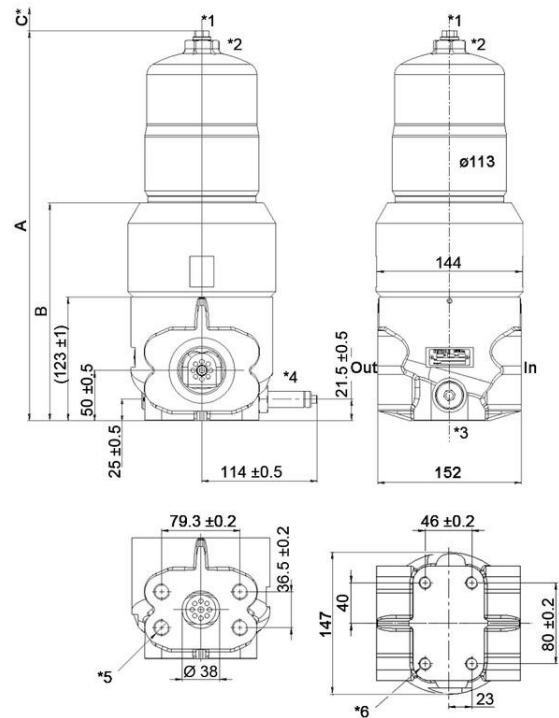

DN 38 according to SAE 1½" 6000 psi  
Flanges, bolts, o-rings not included in delivery!

- C\* = Minimum clearance
- In = Inlet
- Out = Outlet
- \*1 = Venting G¼
- \*2 = SW 30
- \*3 = Drain G½
- \*4 = Visual maintenance indicator
- \*5 = Mounting holes SAE flange 4x M16, 20 mm depth
- \*6 = Mounting holes 4x M12, 17 mm depth

## 9. Dimensions

All dimensions except connection "G..." in mm.

Typ	Connection	A $\pm$ 5	B $\pm$ 2	C
Pi 423016	G1½	299	-	180
Pi 423016 FL	DN 38			
Pi 423025	G1½	386	224	180
Pi 423025 FL	DN 38			
Pi 423040	G1½	538	376	300
Pi 423040 FL	DN 38			

## 10. Installation, operating and maintenance instructions

### 10.1 Filter installation

When installing the filter make sure that sufficient space is available to remove filter element and filter housing. Preferably the filter should be installed with the filter housing pointing upwards. The maintenance indicator must be visible.

### 10.2 Connecting the electrical maintenance indicator

The electrical indicator is connected via a 2-pole appliance plug according to DIN EN 175301-803 with poles marked 1 and 2. The electrical section can be inverted to change from normally open position to normally closed position or vice versa.

### 10.3 When should the filter element be replaced?

- Filters equipped with visual and electrical maintenance indicator:  
During cold starts, the indicator may give a warning signal. Press the red button of the visual indicator once again only after operating temperature has been reached. If the red button immediately pops up again and/or the electrical signal has not switched off after reaching operating temperature, the filter element must be replaced after the end of the shift.
- Filters without maintenance indicator:  
The filter element should be replaced after the trial run or flushing of the system. Afterwards follow instructions of the manufacturer.
- Please always ensure that you have original Filtration Group spare elements in stock: Disposable elements (PS) cannot be cleaned.

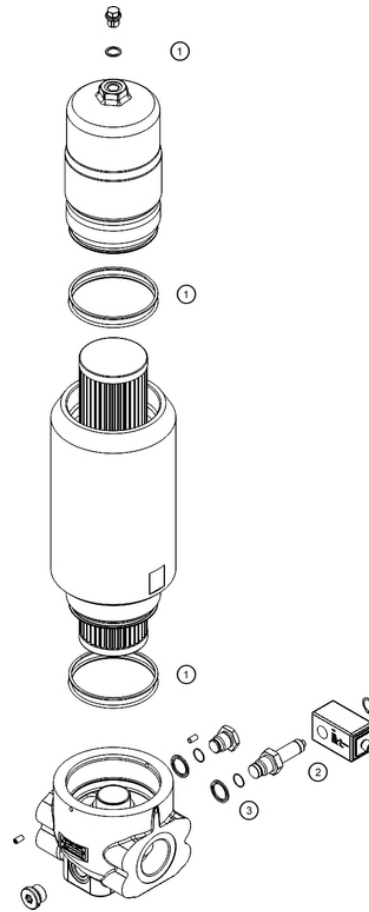

### 10.4 Element replacement

- Stop system and relieve filter from pressure.
- Remove vent and drain plug and empty the filter housing.
- Unscrew the filter housing by turning counter-clockwise. Clean the housing using a suitable cleaning solvent.
- Remove element by pulling up carefully.
- Check o-ring and spigot for damage. Replace, if necessary.
- Make sure that the order number on the spare element corresponds to the order number of the filter name-plate. To ensure no contamination occurs during the exchange of the element first open the plastic bag and push the element over the spigot in the filter head. Now remove plastic bag.
- Oil the threads of the filter housing a little bit and screw into the filter head. Maximum tightening torque for NG 50 to 110 = 60 Nm, for NG 150 to 450 = 100 Nm.
- Check seals of vent and drain plug - if necessary, please replace. Vent the filter housing in pressureless status.  
Torque vent plug 30 Nm.  
Torque drain plug 110 Nm.

## 11. Spare parts list

Order numbers for spare parts		
Position	Type	Order number
①	Seal kit	
	NBR	70382630
	FPM	70382632
	EPDM	70382634
②	Maintenance indicator	
	Visual PiS 3093/5	77669914
	Electrical PiS 3092/5	77669864
	Electrical upper section only	77536550
③	Seal kit for maintenance indicator	
	NBR	77760275
	FPM	77760283
	EPDM	77760291

**Your Contact**

FILCOM GmbH  
Schönbuchstr. 1  
D-73760 Ostfildern

Phone: +49 (0) 711-4413322-0  
Fax: +49 (0) 711-4413322-22  
Mail: [info@filcom.de](mailto:info@filcom.de)

[www.filcom.de](http://www.filcom.de)

