

## Tank top return-line filter Pi 5900

Nominal size 400 and 630  
according to DIN 24550

### 1. Features

#### High performance filters for modern hydraulic systems

- First plastic return filter in nominal sizes 400 l and 630 l
- No corrosion problems due to plastic design
- Provided for tank top installation
- Modular system
- Compact design
- Minimal pressure drop through optimal flow design
- Visual/electrical/electronic maintenance indicator
- Version with flange connections, optional flange adapter with thread
- Quality filters, easy to service
- Equipped with highly efficient Mic or PS filter elements
- Beta rated elements according to ISO 16889 multipass test
- Elements with high differential pressure stability and dirt holding capacity
- NPT- and SAE-connections on request
- Worldwide distribution



## 2. Flow rate/pressure drop curve complete filter

190 mm<sup>2</sup>/s  
33 mm<sup>2</sup>/s

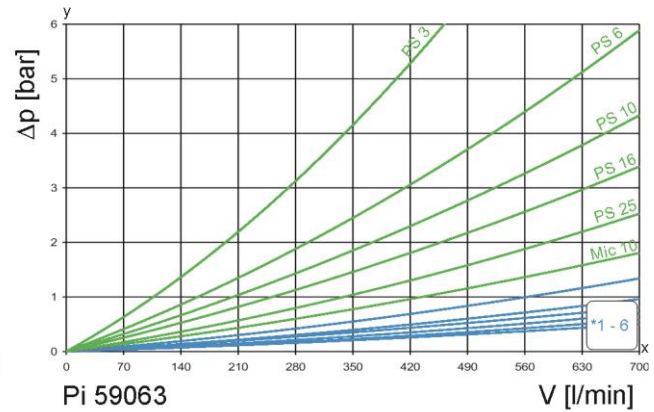
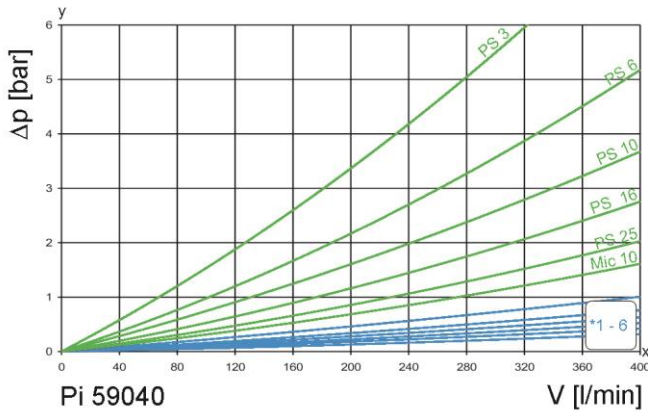

y = differential pressure  $\Delta p$  [bar]  
x = flow rate V [l/min]

\*1 - 6

1. PS 3  
2. PS 6

3. PS 10  
4. PS 16

5. PS 25  
6. Mic 10

## 3. Separation grade characteristics

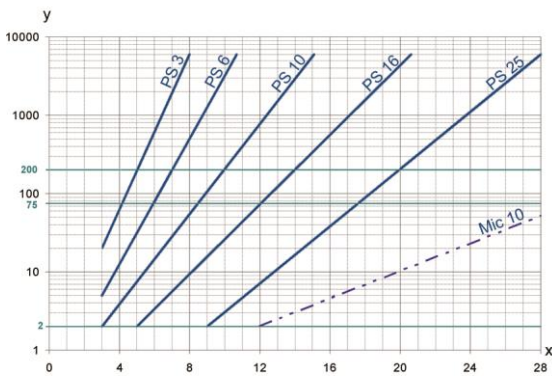

y = beta-value  
x = particle size [ $\mu\text{m}$ ]

determined by multipass tests (ISO 16889)  
calibration according to (NIST)

## 5. Quality assurance

Filtration Group filters and filter elements are produced according to the following international standards:

Norm	Designation
DIN ISO 2941	Hydraulic fluid power filter elements; verification of collapse/burst resistance
DIN ISO 2942	Hydraulic fluid power filter elements; verification of fabrication integrity
DIN ISO 2943	Hydraulic fluid power filter elements; verification material compatibility with fluids
DIN ISO 3723	Hydraulic fluid power filter elements; method for end load test
DIN ISO 3724	Hydraulic fluid power filter elements; verification of flow fatigue characteristics
ISO 3968	Hydraulic fluid power-filters-evaluation of pressure drop versus flow characteristics
ISO 10771.1	Fatigue pressure testing of metal containing envelopes in hydraulic fluid applications
ISO 16889	Hydraulic fluid power filters-multi-pass method for evaluation filtration performance of a filter element

## 4. Filter performance data

tested according to ISO 16889 (multipass test)

PS elements with  
max.  $\Delta p$  10 bar

PS	3	$\beta_{5(C)}$	$\geq 200$
PS	6	$\beta_{7(C)}$	$\geq 200$
PS	10	$\beta_{10(C)}$	$\geq 200$
PS	16	$\beta_{15(C)}$	$\geq 200$
PS	25	$\beta_{20(C)}$	$\geq 200$

10 bar differential pressure

## 6. Symbols

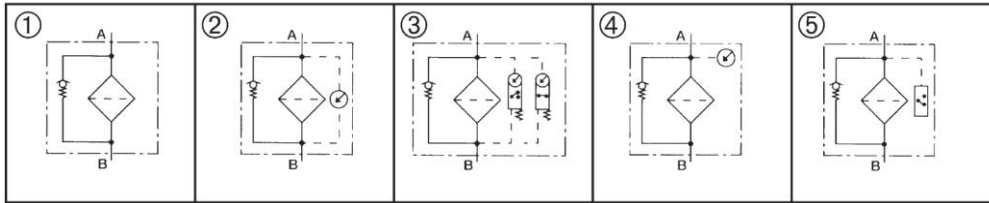

## 7. Order numbers

Example for ordering filters:

1. Housing design	2. Filter element
Volume flow 400 l/min, Bypass valve 3.5 bar, Connection execution 1 = G1½ Type: Pi 59040-056/1	PS 25 NBR Type: Pi 2516 RN

7.1 Housing design*									
Nominal size NG [l/min]	Housing code	① with bypass valve 3.5 bar	① with indicator cavity	② with visual maintenance indicator 2.2 bar	③ with electrical maintenance indicator 2.2 bar	④ with pressure gauge (DM)	⑤ with pressure switch normally open (DSS)	⑤ with pressure switch normally closed (DSO)	with filling connect. (BA)
400 630	- 047								
	- 056								
	- 057								
	- 058								
	- 059								
	- 050								
	- 052								
	- 092								
	- 093								
	- 094								
	- 095								
	- 096								
	- 097								

\* a wider range of executions is available on request

7.2 Connection executions			
Nominal size NG [l/min]	Type	Standard connection according DIN 24550 part 1	/1
400	Pi 59040-...	SAE 2"	G1½
630	Pi 59063-...	SAE 2½"	G1½ or G2

7.3 Filter elements*					
Nominal size NG [l/min]	Order number	Type	Filter material	max. Δp [bar]	Filter surface [cm²]
400	77925050	Pi 13040 RN Mic 10 NBR	Mic 10	10	9450
	77924178	Pi 21040 RN PS 3 NBR	PS 3		9450
	77964083	Pi 22040 RN PS 6 NBR	PS 6		9450
	77924186	Pi 23040 RN PS 10 NBR	PS 10		9450
	77963663	Pi 24040 RN PS 16 NBR	PS 16		9450
	77960255	Pi 25040 RN PS 25 NBR	PS 25		9450
630	77925068	Pi 13063 RN Mic 10 NBR	Mic 10	10	15500
	77924194	Pi 21063 RN PS 3 NBR	PS 3		13515
	77964091	Pi 22063 RN PS 6 NBR	PS 6		13515
	77924202	Pi 23063 RN PS 10 NBR	PS 10		13515
	77963671	Pi 24063 RN PS 16 NBR	PS 16		13515
	77960263	Pi 25063 RN PS 25 NBR	PS 25		13515

\* a wider range of element types is available on request

## 8. Technical specifications

Design:	Tank top installation
Nominal pressure:	10 bar (140 psi)
Test pressure:	15 bar (217 psi)
Temperature range:	-10 °C to +60 °C
	(other temperature ranges on request)
Bypass setting:	$\Delta p$ 3.5 bar $\pm$ 10 %
Filter head material:	PA 6 GF30
Filter housing material:	PA 6 GF30
Filter cover material:	PA 6 GF30
Maintenance indicator setting:	$\Delta p$ 2.2 bar $\pm$ 0.3
Electrical data of maintenance indicator:	
Maximum voltage:	250 V AC/200 V DC
Maximum current:	1 A
Contact load:	70 W
Type of protection:	IP 65 in inserted and secured status
Contact:	normally open/closed
Cable sleeve:	M20x1.5

The switching function can be changed by turning the electric upper part by 180° (normally closed contact or normally open contact). The state on delivery is a normally closed contact. By inductivity in the direct current circuit the use of suitable protection circuit should be considered. Further maintenance indicator details and designs are available in the maintenance indicator data sheet..

We draw attention to the fact that all values indicated are average values and do not always occur in specific cases of application. Our products are continually being further developed. Values, dimensions and weights can change as a result of this. Our specialized department will be pleased to offer you advice.

We recommend you to contact us concerning applications of our filters in areas governed by the EU Directive 94/9 EC (ATEX 95). The standard version can be used for liquids based on mineral oil (corresponding to the fluids in Group 2 of Directive 97/23 EC Article 9). If you consider to use other fluids please contact us for additional support..

Subject to technical alteration without prior notice.

- 3 Pressure gauge or switch
- 4 Standard maintenance indicator visual PiS 3084, Standard maintenance indicator electrical PiS 3085 (further executions see data sheet maintenance indicator)
- 6 Quick-release coupling

Optional threaded connections:

- II G $\frac{1}{4}$
- III M20x1.5 o. G $\frac{1}{2}$
- IV M30x1.5

- B2/B3\* Optional extensions (other lengths on request)
- C\*\* Clearance required
- D\*\*\* Number of bypass valves

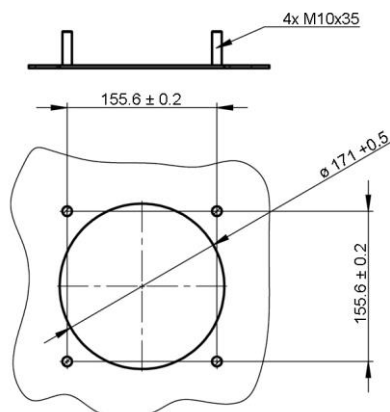
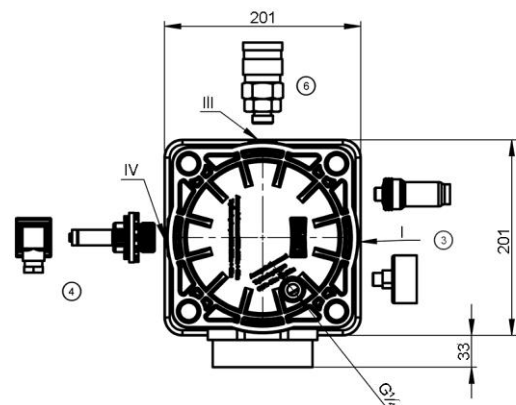
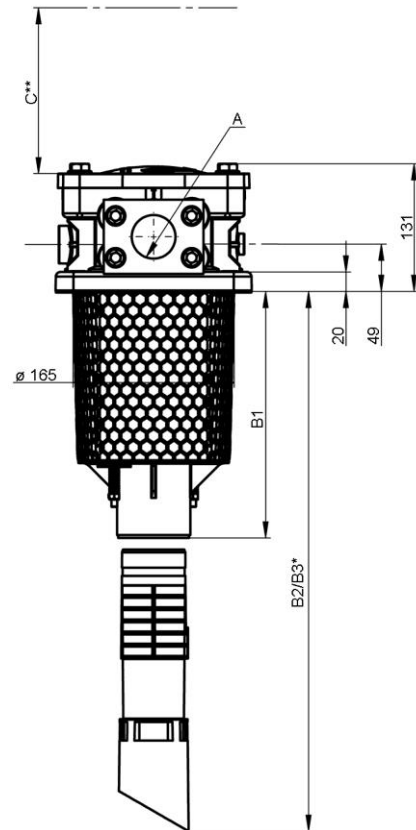
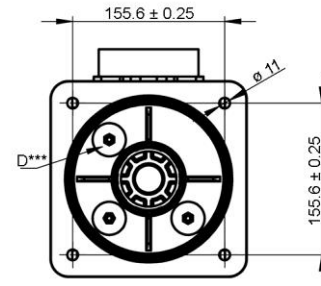

Fig. Tank cover connection

## 9. Dimensions



All Dimensions except "A" in mm.

Type	A	B1	B2*	B3*	C**	D***	Wt. [kg]
Pi 59040	G1 $\frac{1}{2}$	253	436	613	270	3	5
Pi 59063	G1 $\frac{1}{2}$ or G2	403	586	763	420	4	5.3

## 10. Installation, operating and maintenance instructions

### 10.1 Filter installation

When installing the filter make sure that:

- a) sufficient space is available to remove filter element and filter housing.
- b) the mounting hole in the tank top is not excessively large, to ensure proper sealing (see fig. Tank cover connection).
- c) the filter is free of tension after installation.

Preferably the return-line filter is to be installed with the filter housing pointing downwards.

### 10.2 Connecting the electrical maintenance indicator

The electrical maintenance indicator is connected via a 2-pole appliance plug according to DIN EN 17 5301-803 with poles marked 1 and 2. The electrical section can be inverted to change from normally open position to normally closed position or vice versa.

### 10.3 When must the filter element be replaced?

1. Filters equipped with visual and/or electrical maintenance indicator: During cold starts, the indicator may give a warning signal. Press the button of the visual indicator once again only after operating temperature has been reached. If the red button immediately pops up again and/or the electrical signal has not switched off after reaching operating temperature, the filter element must be replaced after the end of the shift.
2. The filter element should be replaced after trial run or flushing of the system. Afterward follow instructions of the manufacturer.
3. Please always ensure that you have original Filtration Group spare elements in stock: Disposable elements (PS and Mic) cannot be cleaned.

### 10.4 Element replacement

1. Stop system and relieve filter from pressure.
2. Remove the screws from the filter cover and pull it upwards.
3. Remove filter element with a side-to-side motion.
4. Clean the housing using a suitable cleaning solvent.
5. Check O-ring on filter cover and filter housing for damage. Replace, if necessary.
6. Make sure that the order number on the spare element corresponds to the order number of the filter name-plate.
7. Remove filter element from the plastic bag and reassemble filter in reverse order (items 1 to 3).

## 11. Spare parts list

Order numbers for spare parts		
Position	Type	Order number
①	Seal kit for housing	
	NBR	72471515
②	FPM	72471516
	EPDM	72471517
③	Pressure gauge	78381998
	Pressure switch normally open	77845845
	Pressure switch normally closed	77870595
④	Maintenance indicator	
	Visual PiS 3084/2.2	77737802
	Electrical PiS 3085/2.2	77738032
⑤	Seal kit for maintenance indicator + blind plug	
	NBR	78383382
	FPM	78383390
⑥	EPDM	78383408
	Quick-release coupling	77965130

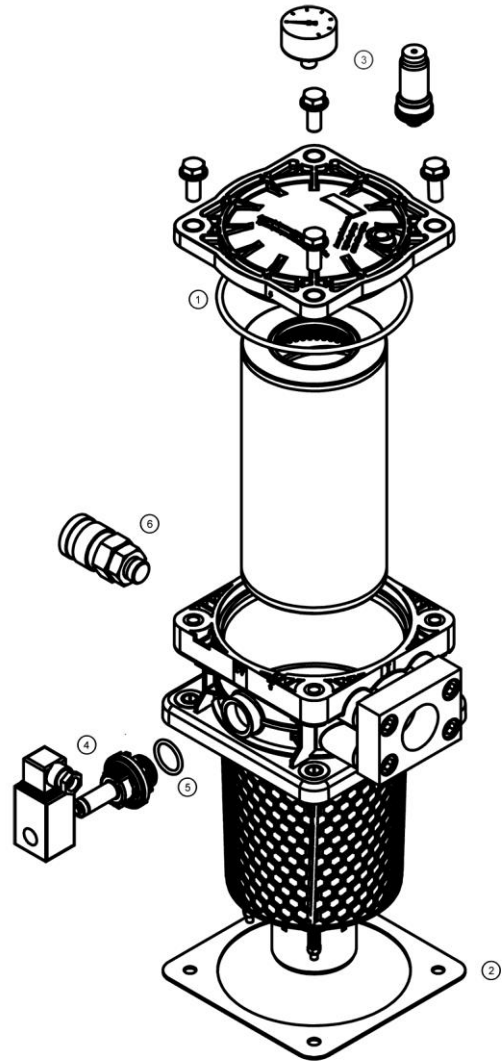

### Your Contact

FILCOM GmbH  
Schönbuchstr. 1  
D-73760 Ostfildern

Phone: +49 (0) 711-4413322-0  
Fax: +49 (0) 711-4413322-22  
Mail: info@filcom.de

www.filcom.de

**FILCOM**<sup>®</sup>  
FILTRATION