

## Electrical Maintenance Indicators

### PiS 3200

with DIN plug connection

#### 1. Features

Filter elements are economically used only if their dirt holding capacity is fully exploited. A reliable indication of the optimal time to replace the element is therefore vital.

These maintenance indicators include a DIN EN 175301-803 plug connection and are available in normally open, normally closed or change-over contact type version.

Thanks to the Filtration Group modular system these maintenance indicators can be used with all Filtration Group pressure filters.



## 2. Differential pressure indicators

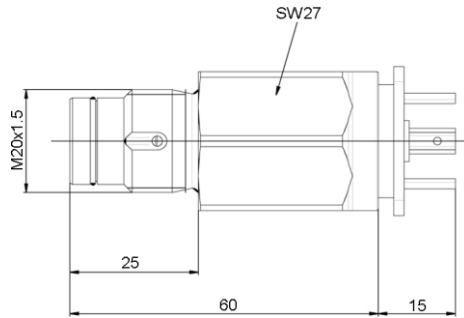

Fig. 1

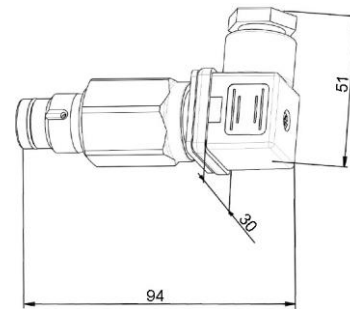

Fig. 2

Differential pressure indicators									
Nominal pressure [bar]	Temperature [°C]	Type	Order number	Indicator setting [bar]	Indication	Contact-type*	Fig.	Material housing	Material plug connection
160	-30 - +120	PiS 3209	70520470	2.2	electr.	norm. closed	1 + 2	Al	PA
		PiS 3212	70520472			norm. open	1 + 2		
		PiS 3215	70520477			3	1 + 2		
400	-30 - +120	PiS 3210	70520471	5.0	electr.	norm. closed	1 + 2	CuZn	PA
		PiS 3213	70520476			norm. open	1 + 2		
		PiS 3216	70520478			3	1 + 2		

\*Contact type

1 Normally open or normally closed; 1 setting point; DIN EN 175301-803; max. 48 V DC; max. 0.5 A

3 Change-over contact; 1 setting point; DIN EN 175301-803; max. 48 V; max. 0.5 A

## 3. Technical specifications

### 3.1 Contact type normally open/normally closed

Contact type 1

Types PiS 3209, 3210

normally closed

Types PiS 3212, 3213

normally open

Material seal:

NBR\*

Max. voltage:

48 V DC

Max. current:

0.5 A

Contact load:

10 VA

Type of protection:

IP 65 in inserted and secured status

Plug connection:

DIN EN 175 301-803

\* other seals on request

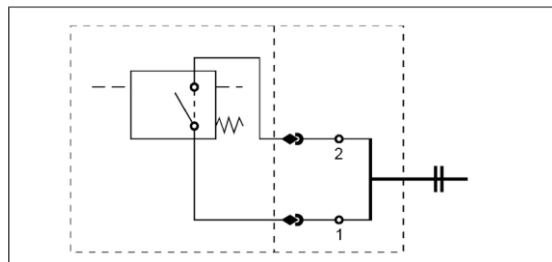

### 3.2 Contact type Change-over contact

Contact type 3

Types PiS 3215, 3216

change-over contact

for further technical details see 3.1

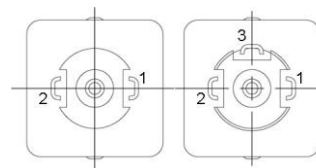

normally closed/normally open-change-over contact

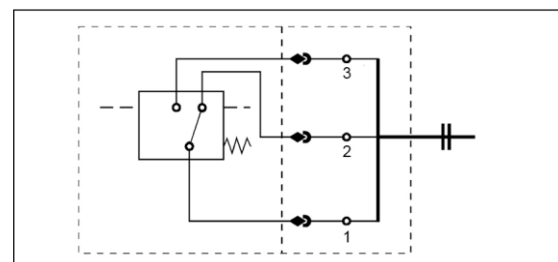

### Your Contact

FILCOM GmbH  
Schönbuchstr. 1  
D-73760 Ostfildern

Phone: +49 (0) 711-4413322-0  
Fax: +49 (0) 711-4413322-22  
Mail: info@filcom.de

www.filcom.de

**FILCOM**<sup>®</sup>  
FILTRATION