

Coalescer Filter

PiW 1975

1. Description

The Coalescer filter has been specially designed to separate water from hydraulic fluids.

According to VDMA standard sheet 24568, the amount of water in HE pressure fluids has to be kept below 1000 ppm (0.1 %). HLP fluids should not contain any free water at all. Free water always causes turbidity which can be seen by the human eye. Physically, turbidity is a two-phase mixture (emulsion) in which small droplets of water are present in the pressure fluid. For this reason, it is advisable to carry out a mechanical separation of these water droplets; this technique is based on the coalescer - principle. The droplets are collected in various layers and brought together into larger units. The water drops thus formed are several millimetres in diameter.

After leaving the coalescer layer, the drops come in contact with a special hydrophobic fabric, where the separation from the pressure fluid takes place. The water is removed from the circuit by means of sedimentation. It is important that a certain differential pressure is not exceeded during the process. The viscosity also needs to be taken into account to ensure proper operation. The maximum viscosity for effective water separation is approx. 68 mm²/s. The coalescer works best if the pressure fluids contain a minimal amount of emulsifying additives. The bottom line: in systems that are frequently at risk for water ingress, expensive special oils can be replaced by simple, cost-effective pressure fluids.

Characteristics:

- Mechanical separation of water droplets - coalescer principle
- Water removing by means of sedimentation
- Expensive special oils can be replaced by simple, cost-effective pressure fluids
- Worldwide distribution



2. Flow rate

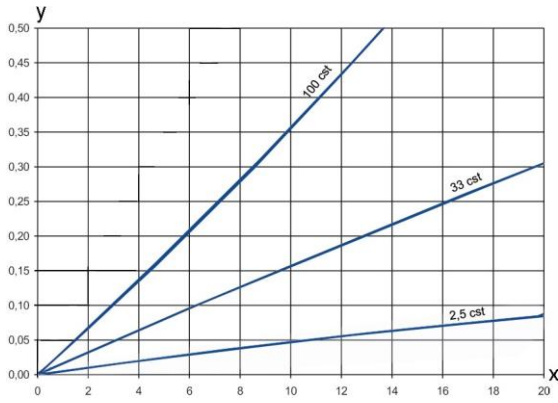

y = differential pressure in bar
x = flow rate in l/min

3. Water solubility

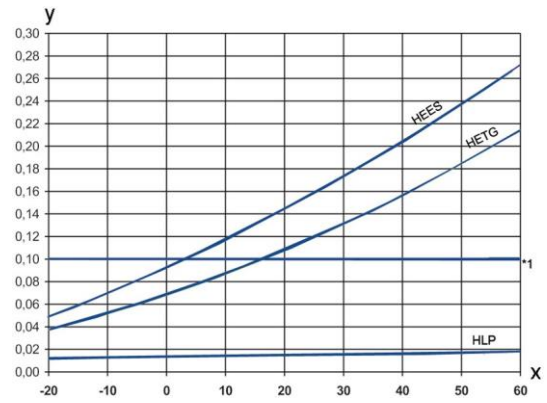

X = temperature [°C]
y = water solubility (%)

1* VDMA-threshold

4. Quality assurance

Filtration Group filters and filter elements are produced according to the following international standards:

Norm	Designation
DIN ISO 2941	Hydraulic fluid power filter elements; verification of collapse/burst resistance
DIN ISO 2942	Hydraulic fluid power filter elements; verification of fabrication integrity
DIN ISO 2943	Hydraulic fluid power filter elements; verification of material compatibility with fluids
DIN ISO 3723	Hydraulic fluid power filter elements; method for end load test
DIN ISO 3724	Hydraulic fluid power filter elements; verification of flow fatigue characteristics
ISO 3968	Hydraulic fluid power filters; evaluation of pressure drop versus flow characteristics
ISO 10771.1	Fatigue pressure testing of metal containing envelopes in hydraulic fluid applications
ISO 16889	Hydraulic fluid power filters; multipass method for evaluation filtration performance of a filter element

5. Symbols

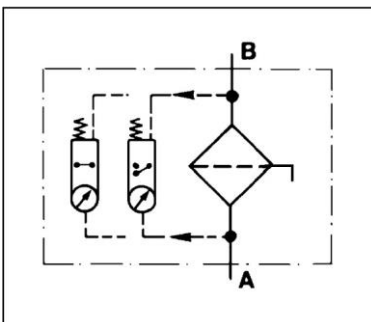

6. Order number

Housing Design	Spare parts
complete with visual/electrical indicator, demister and coalescer element Type: PiW 1975/E-Coalescer Order number: 76334031	Type: 853 275 Coalescer Order number: 76345300

7. Technical specifications

Design:	line mounting filter
Nominal pressure:	6 bar (90 psi)
Test pressure:	8 bar (110 psi)
Temperature range:	-10 °C to +80 °C (other temperature ranges on request)
Filter housing material:	St
Sealing material:	NBR/Cu
Maintenance indicator setting:	Δp 1.2 bar \pm 0.2 bar
Electrical data of maintenance indicator:	
Maximum voltage:	250 V AC/200 V DC
Maximum current:	1 A
Contact load:	70 W
Type of protection:	IP 65 in inserted and secured status
Contact:	normally open/closed
Cable sleeve:	M 20 x 1.5

The switching function can be changed by turning the electric upper part by 180° (normally closed contact or normally open contact). The state on delivery is a normally closed contact. By inductivity in the direct current circuit the use of suitable protection circuit should be considered. Further maintenance indicator details and designs are available in the maintenance indicator data sheet.

We draw attention to the fact that all values indicated are average values which do not always occur in specific cases of application. Our products are continually being further developed. Values, dimensions and weights can change as a result of this. Our specialized department will be pleased to offer you advice.

We recommend you to contact us concerning applications of our filters in areas governed by the EU Directive 94/9 EC (ATEX 95). The standard version can be used for liquids based on mineral oil (corresponding to the fluids in Group 2 of Directive 97/23 EC Article 9). If you consider to use other fluids please contact us for additional support.

Subject to technical alteration without prior notice.

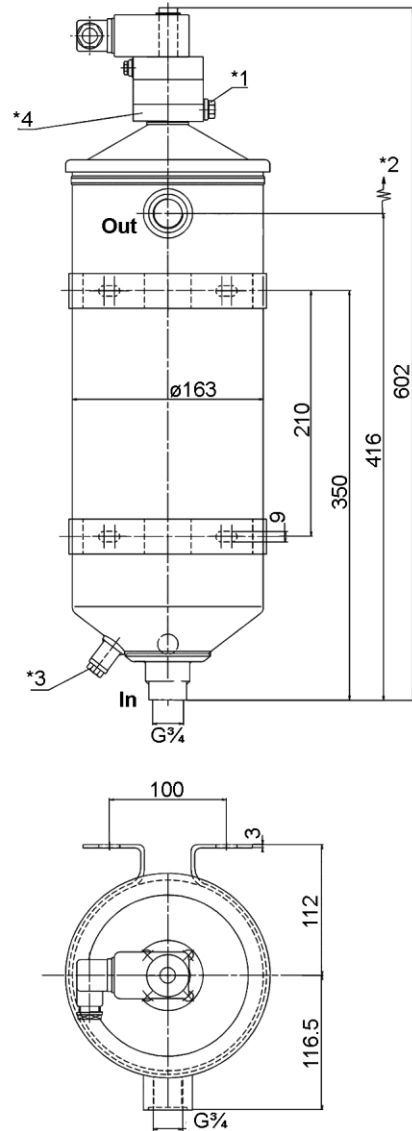

- In = Inlet
- Out = Outlet
- *1 vent screw
- *2 extension degree 400
- *3 drain screw G $\frac{3}{4}$ drawn 90° shifted
- *4 SW 36 for filter maintenance

Weight 8 kg

8. Installation, operating and maintenance instructions

8.1 Filter installation

When installing filter make sure that sufficient space is available to remove filter element.

Install filter vertical so that the separated water can flow down and can be discharged.

8.2 Connecting the electrical maintenance indicator

The electrical indicator is connected via a 2-pole appliance plug according to DIN EN 175301-803, with poles marked 1 and 2. The electrical section can be inverted to change from normally open to normally closed position and vice versa.

8.3 Operating instruction

The max. viscosity for an effective water separation should not exceed 68 mm²/s. The coalescer should run with a differential pressure of approx. 0.3 bar, that means that the volumetric flow is determined by the viscosity of the oil. To prevent premature contamination of the coalescer, a protective filter with a retention rate of $\beta_{7(C)} 002 \geq$ should be installed before the coalescer, because the coalescer element is so fine and therefore very sensitive to dirt. In order to recognise the separated water, a transparent water-detection device with a tap should be mounted to the cone of the filter housing.

8.4 When does the coalescer element need to be replaced?

A differential pressure indicator with a switching level of Δp 1.2 bar is mounted at the top of the filter housing. As already mentioned above, the filter should run at Δp of approx. 0.3 bar. During cold starts, the indicator may give a warning signal. Press the red button of the visual indicator once again only after operating temperature has been reached. If the red button immediately pops up again and/or the electrical signal has not switched off after reaching operating temperature, the coalescer must be replaced after the end of the shift.

Remark: Please note permissible operating pressure of the housing.

8.5 Replacing the coalescer element

Before an element can be replaced, the entire system needs to be shut down and the filter released from the pressure. Use the water tap to empty the housing. The differential pressure indicator (1) also serves as a cover screw which needs to be removed to take off the cover (2). Remove the coalescer element (3) from the housing. The separator only needs to be replaced, if it is damaged.

Push a new coalescer element over the centre pipe in the housing. Check seals in the lid-cover for possible damages, replace if necessary. Place the top cover back on top of the housing and tighten it together with the differential pressure indicator.

Close the water tap.

The venting of the filter will be accomplished by the vent screw on the Δp indicator. Please unscrew the vent screw 1-2 turn until fluid emerge. Tight vent screw.

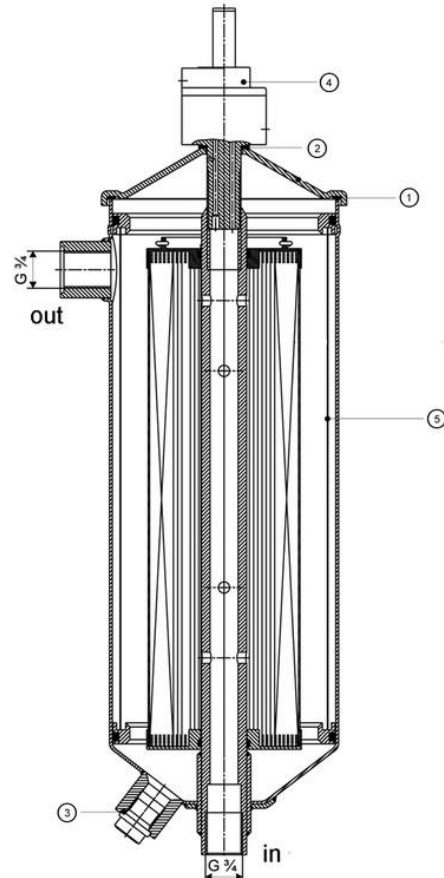

9. Spare parts list

Order number for spare parts		
Pos.	Type	Order number
① - ③	Seal kit for housing	
	NBR	76375364
④	Maintenance indicator	
	Visual PiS 3503/1,2	76375372
	Electrical PiS 3304/1,2	76375380
	Electrical upper section only	77536550
	Seal kit for maintenance indicator	
	NBR	78389280
⑤	Demister	76333876

Your Contact

FILCOM GmbH
Schönbuchstr. 1
D-73760 Ostfildern

Phone: +49 (0) 711-4413322-0
Fax: +49 (0) 711-4413322-22
Mail: info@filcom.de

www.filcom.de

FILCOM[®]
FILTRATION