

## Coalescer Filter

### PiW 2175

#### 1. Features

The Coalescer filter has been specially designed to separate water from hydraulic fluids, diesel and marine diesel oil.

According to VDMA standard sheet 24568, the amount of water in HE pressure fluids has to be kept below 1000 ppm (0.1 %). HLP fluids should not contain any free water at all. Free water always causes turbidity which can be seen by the human eye. Physically, turbidity is a two-phase mixture (emulsion) in which small droplets of water are present in the pressure fluid. For this reason, it is advisable to carry out a mechanical separation of these water droplets; this technique is based on the coalescer - principle. The droplets are collected in various layers and brought together into larger units. The water drops thus formed are several millimetres in diameter.

After leaving the coalescer layer, the drops come in contact with a special hydrophobic fabric, where the separation from the pressure fluid takes place. The water is removed from the circuit by means of sedimentation. It is important that a certain differential pressure is not exceeded during the process. The viscosity also needs to be taken into account to ensure proper operation. The maximum viscosity for effective water separation is approx. 68 mm<sup>2</sup>/s. The coalescer works best if the pressure fluids contain a minimal amount of emulsifying additives. The bottom line: in systems that are frequently at risk for water ingress, expensive special oils can be replaced by simple, cost-effective pressure fluids.

#### Characteristics:

- Mechanical separation of water droplets - coalescer principle
- Water removing by means of sedimentation
- Expensive special oils can be replaced by simple, cost-effective pressure fluids
- Worldwide distribution



## 2. Functional description

### 2.1 Principle of the process

Liquid flows through the coalescer element. Minute water droplets "coalesce" there to form larger drops and any impurities are retained. These large drops then sink to the bottom and are guided to the water drain by a hydrophobic cloth.

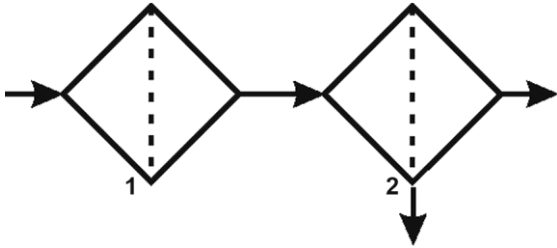

1 = Coalescer  
2 = Droplet separator

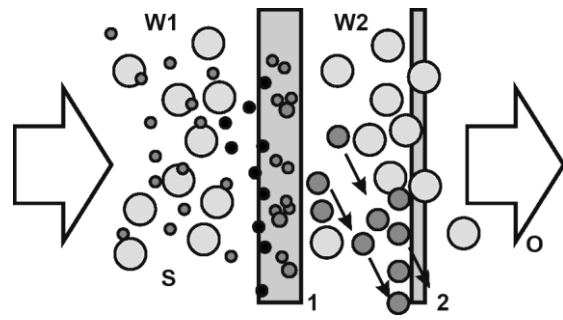

W1 = little droplets  
W2 = large droplets  
1 = Coalescer  
2 = Droplet separator  
O = Öl

### 2.2 Main components



① Maintenance indicator  
② Vent screw / air release valve (optional)  
③ Cover  
④ Housing  
⑤ 2 water level sensors

### 2.3 Functional description

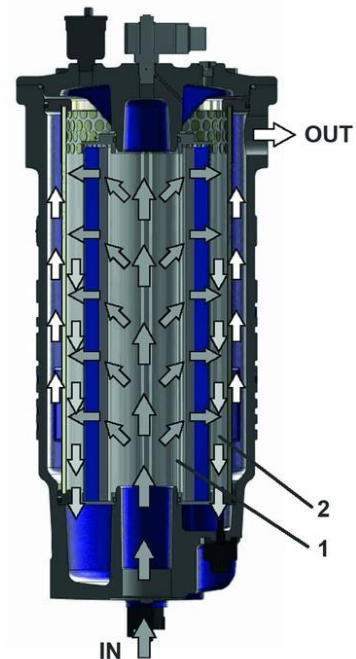

- Dirty liquid flows into the housing (IN).
- The water droplets coalesce to form larger drops and any impurities are retained by the coalescer element (depth filter).
- Water is separated by the hydrophobic cloth and collects in a reservoir at the bottom of the filter housing.
- Clean liquid flows through the outlet (OUT).

### 3. Flow rate

— 500 mm<sup>2</sup>/s  
— 190 mm<sup>2</sup>/s  
— 33 mm<sup>2</sup>/s

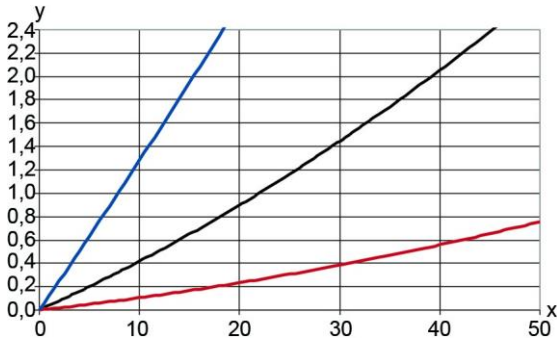

y = differential pressure in bar  
 x = flow rate in l/min

### 4. Water solubility

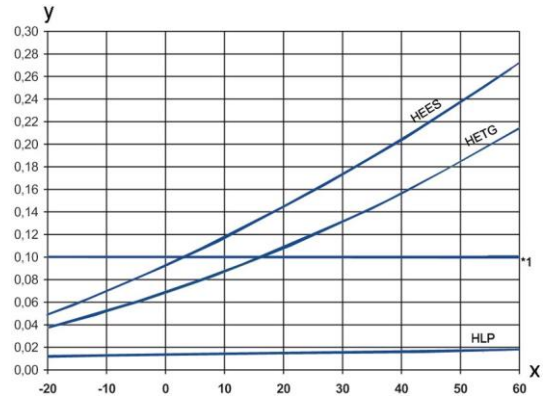

x = temperature in °C  
 y = water solubility (%)  
 \*1 VDMA-threshold

### 5. Quality assurance

Filtration Group filters and filter elements are produced according to the following international standards:

Norm	Designation
DIN ISO 2941	Hydraulic fluid power filter elements; verification of collapse/burst resistance
DIN ISO 2942	Hydraulic fluid power filter elements; verification of fabrication integrity
DIN ISO 2943	Hydraulic fluid power filter elements; verification of material compatibility with fluids
DIN ISO 3723	Hydraulic fluid power filter elements; method for end load test
DIN ISO 3724	Hydraulic fluid power filter elements; verification of flow fatigue characteristics
ISO 3968	Hydraulic fluid power filters; evaluation of pressure drop versus flow characteristics
ISO 10771.1	Fatigue pressure testing of metal containing envelopes in hydraulic fluid applications
ISO 16889	Hydraulic fluid power filters; multipass method for evaluation filtration performance of a filter element

### 6. Symbol

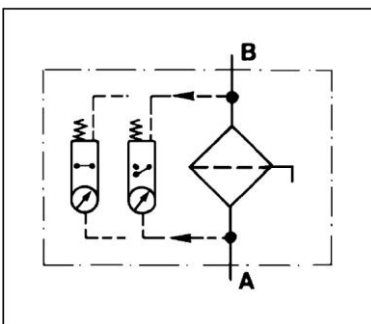

### 7. Order numbers

Example for ordering filters:

1. Filter housing	2. Filter element
complete with visual/electrical maintenance indicator, droplet separator and coalescer element Type: PiW 2175 Order number: 72356609	Type: KE 2629 E1 COA Order number: 76361281

## 8. Technical specifications

Design:	in-line filter
Nominal pressure:	16 bar (230 psi)
Test pressure:	24 bar (340 psi)
Temperature range:	+5 °C to +90 °C (other temperature ranges on request)
Filter housing material:	nodular cast iron
Sealing material:	NBR
Water collection chamber:	approx. 2 l
Maintenance indicator setting:	$\Delta p$ 2.2 bar $\pm$ 0,2 bar
Electrical data of maintenance indicator:	
Max. voltage:	250 V AC/200 V DC
Max. current:	1 A
Contact load:	70 W
Type of protection:	IP 65 in inserted and secured status
Contact:	normally open/closed
Cable sleeve:	M20x1.5

The switching function can be changed by turning the electric upper part by 180° (normally closed contact or normally open contact). The state on delivery is a normally closed contact. By inductivity in the direct current circuit the use of suitable protection circuit should be considered. Further maintenance indicator details and designs are available in the maintenance indicator data sheet.

We draw attention to the fact that all values indicated are average values and do not always occur in specific cases of application. Our products are continually being further developed. Values, dimensions and weights can change as a result of this. Our specialized department will be pleased to offer you advice.

We recommend you to contact us concerning applications of our filters in areas governed by the EU Directive 94/9 EC (ATEX 95). The standard version can be used for liquids based on mineral oil (corresponding to the fluids in Group 2 of Directive 97/23 EC Article 9). If you consider to use other fluids please contact us for additional support.

Subject to technical alteration without prior notice.

## 9. Dimensions

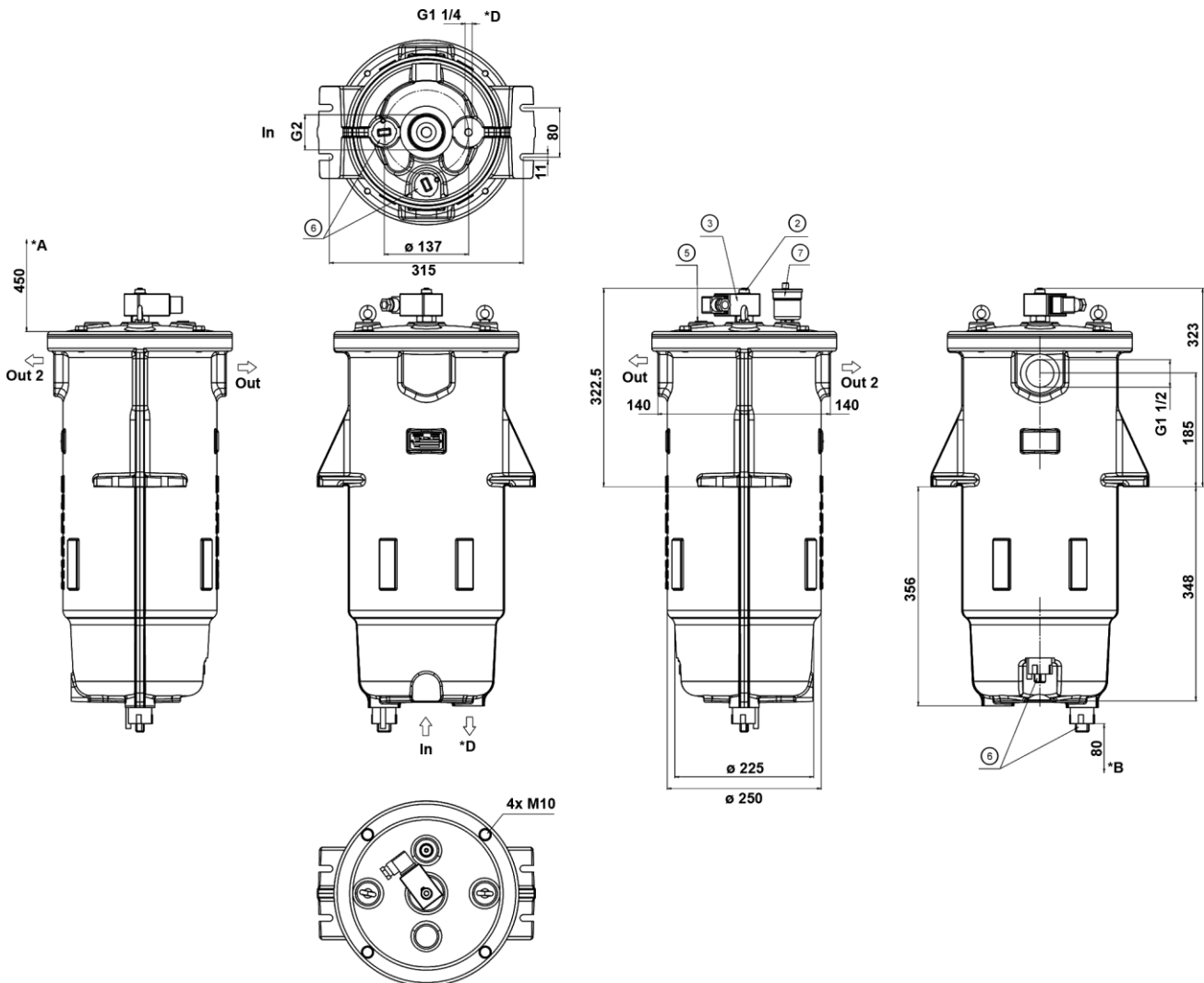

## 9.1 Caption for dimensions

In	Inlet	②	Maintenance indicator visual
Out	Outlet	③	Maintenance indicator electrical upper section
Out 2	Outlet optional	④	Vent screw (30 Nm)
*A	Clearance required for filter element	⑤	Water level sensors
*B	Clearance required for wires	⑦	Air release valve optional
*D	Water drain		

## 10. Installation, operating and maintenance instructions

### 10.1 Filter installation

When installing the filter make sure that sufficient space is available to remove filter element and filter housing. Install filter vertical so that the separated water can flow down and can be discharged.

### 10.2 Connecting the electrical maintenance indicator

The electrical indicator is connected via a 2-pole appliance plug according to DIN EN 175301-803 with poles marked 1 and 2. The electrical section can be inverted to change from normally open position to normally closed position or vice versa.

### 10.3 Operating instruction

The max. viscosity for an effective water separation should not exceed 68 mm<sup>2</sup>/s. The coalescer should run with a differential pressure of approx. 0.3 bar, that means that the volumetric flow is determined by the viscosity of the oil. The separated water will be collected in the PiW 2175 (max. 2 l). The Water can be discharged automatically by using the water level sensor. In order to recognize the separated water, a transparent water-detection device with a tap or so called warning indicator should be mounted.

**Remark:** Please note permissible operating pressure of the housing.

### 10.4 When should the coalescer element be replaced?

A differential pressure indicator with a switching level of  $\Delta p$  2.2 bar is mounted at the top of the filter housing. During cold starts, the indicator may give a warning signal. Press the red button of the visual indicator once again only after operating temperature has been reached. If the red button immediately pops up again and/or the electrical signal has not switched off after reaching operating temperature, the coalescer must be replaced after the end of the shift.

As already mentioned above, the filter should run at  $\Delta p$  of approx. 0.3 bar. The flow rate/pressure drop curves show the flow rates according to the viscosity. If the indicator may give a warning signal, the coalescer element have to be changed.

### 10.5 Element replacement

Stop system and relieve filter from pressure. Use the water tap to empty the housing. Unscrew the cover and change the coalescer element. Check seals in the lid-cover for possible damages, replace if necessary. Place the top cover back on top of the housing and tighten it. Close the water tap.

The venting occurs by a venting screw. Tighten the venting screw when the fluid flows out of the venting bore.

## 11. Spare parts list

Order numbers of spare parts		
Position	Type	Order number
① ② ⑤	Seal kit for filter housing incl. visual maintenance indicator and venting screw	72348122
	Maintenance indicator	
③	Electrical PiS 3092/2.2	77669856
	Electrical upper section only	77536550
④	Droplet separator	72356964
⑥	Water level sensor	72348133
⑦	Coalescer element	76361281

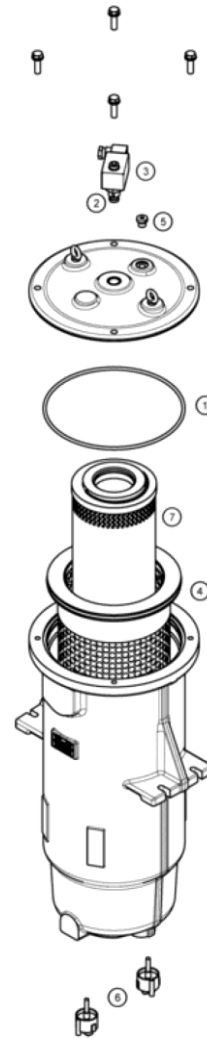

### Your Contact

FILCOM GmbH  
 Schönbuchstr. 1  
 D-73760 Ostfildern

Phone: +49 (0) 711-4413322-0  
 Fax: +49 (0) 711-4413322-22  
 Mail: [info@filcom.de](mailto:info@filcom.de)

[www.filcom.de](http://www.filcom.de)

**FILCOM**<sup>®</sup>  
 FILTRATION