

## Duplex Filter Pi 21430

Nominal pressure 100 bar (1452 psi), nominal size 300

### 1. Features

#### High performance filters for modern lubrication and hydraulic systems

- Modular system
- Compact design
- Minimal pressure drop through optimal flow design
- Visual/electrical/electronic maintenance indicator
- Threaded and SAE-flange connections
- Change over valve on upstream side
- Ergonomic switch-over handle with safety lock and pressure compensation
- User-optimized one-hand-operation
- Equipped with highly efficient Drg filter elements
- Beta rated elements according to ISO 16889 multipass test
- Elements with high differential pressure stability and dirt holding capacity
- NPT- and SAE-connections on request
- Worldwide distribution



## 2. Quality assurance

Filtration Group filters and filter elements are produced according to the following international standards:

Norm	Designation
DIN ISO 2941	Hydraulic fluid power filter elements; verification of collapse/burst pressure
DIN ISO 2942	Hydraulic fluid power filter elements; verification of fabrication integrity
DIN ISO 2943	Hydraulic fluid power filter elements; verification of material compatibility with fluids
DIN ISO 3723	Hydraulic fluid power filter elements; method for end load test
DIN ISO 3724	Hydraulic fluid power filter elements; verification of flow fatigue characteristics
ISO 3968	Hydraulic fluid power-filters-evaluation of pressure drop versus flow characteristics
ISO 10771.1	Fatigue pressure testing of metal containing envelopes in hydraulic fluid applications
ISO 16889	Hydraulic fluid power filters; multipass method for evaluation filtration performance of a filter element

## 3. Symbols

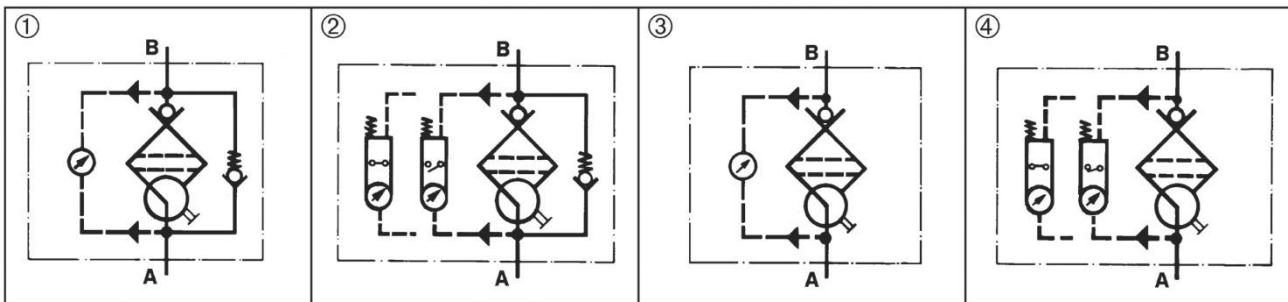

## 4. Order numbers

Example for ordering filters:

1. Filter housing	2. 2x Filter element
V = 300 l/min and electrical maintenance indicator Type: Pi 21430-069 Order number: 72464324	Drg 40 Type: Pi 8330 Drg 40 Order number: 77718802

### 4.1 Housing design

Nominal size NG [l/min]	Order number	Type	① with bypass valve and visual indicator	② with bypass valve and electrical indicator	③ with visual indicator	④ with electrical indicator
300	72464319	Pi 21430-057				
	72464320	Pi 21430-058				
	72464321	Pi 21430-068				
	72464324	Pi 21430-069				
	72464325	Pi 21430-057 FKM				
	72464326	Pi 21430-058 FKM				
	72464327	Pi 21430-068 FKM				
	72464329	Pi 21430-069 FKM				
	72464332	Pi 21430-057 FL				
	72464333	Pi 21430-058 FL				
	72464334	Pi 21430-068 FL				
	72464335	Pi 21430-069 FL				
	72464336	Pi 21430-057 FL FKM				
	72464337	Pi 21430-058 FL FKM				
	72464338	Pi 21430-068 FL FKM				
72464339	Pi 21430-069 FL FKM					

When filter with non bypass configuration is selected, the collapse pressure of the element must not be exceeded.

#### 4.2 Filter elements\*

Nominal size NG [l/min]	Order number	Type	Filter material	max. $\Delta p$ [bar]	Filter surface [cm <sup>2</sup> ]
300	77718810	Pi 8130 Drg 10	Drg 10	20	4280
	77680952	Pi 8230 Drg 25	Drg 25		4280
	77718802	Pi 8330 Drg 40	Drg 40		4280
	77681042	Pi 8430 Drg 60	Drg 60		2975
	77689078	Pi 8530 Drg 100	Drg 100		4280
	77669510	Pi 8630 Drg 200	Drg 200		2975
	77718786	Pi 8730 Drg 300	Drg 300		2975
	77718794	Pi 8830 Drg 500	Drg 500		4280

\*other element types on request

## 5. Technical specifications

Design:	in-line filter
Operating pressure:	2x 10 <sup>6</sup> load changes 100 bar (1452 psi)
Test pressure:	150 bar (2170 psi)
Temperature range:	-10 °C to +120 °C (other temperature ranges on request)
Bypass opening pressure:	$\Delta p$ 3.5 bar $\pm$ 10 %
Filter head material:	GGG
Filter bowl material:	St
Sealing material:	NBR/FKM/EPDM
Activating pressure of visual/electrical differential maintenance indicator:	$\Delta p$ 2.2 bar $\pm$ 10 %
Electrical data of maintenance indicator:	
Maximum voltage:	250 V AC/200 V DC
Maximum current on contact:	1 A
Inrush current:	70 W
Type of protection:	IP 65 when inserted and secured
Contact:	bistable
Cable connection:	M20x1.5

The switching function can be changed by turning the electric upper part by 180° (normally closed contact or normally open contact). The state on delivery is a normally closed contact. The use of quenching circuits must be checked in the case of inductivity in the DC current circuit. The maintenance indicator data sheet contains further information and additional maintenance indicator versions.

We draw attention to the fact that all values indicated are average values which do not always occur in specific cases of application. Our products are continually being further developed. Values, dimensions and weights can change as a result of this. Our specialized department will be pleased to offer you advice.

We recommend you to contact us concerning applications of our filters in areas governed by the EU 2014/34/EU (ATEX 95). The standard version can be used for liquids based on mineral oil (corresponding to the fluids in Group 2 of Directive 2014/68 EU Article 13). If you consider to use other fluids please contact us for additional support.

Subject to technical alteration without prior notice.

## 6. Dimensions

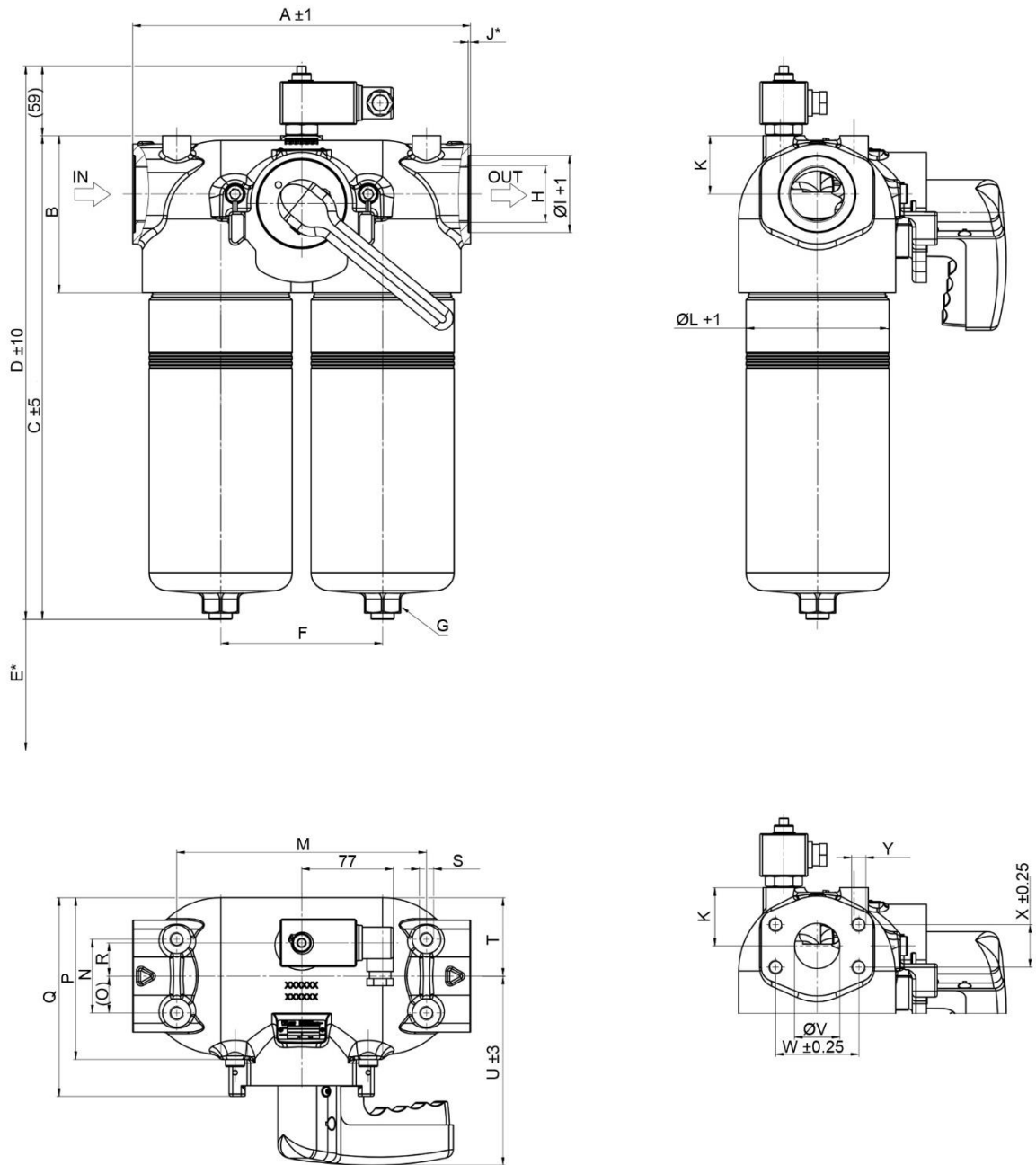

In Inlet  
Out Outlet

E\* Minimum clearance required for element change  
J\* Only with threaded version

All dimensions except "H" in mm.

Type	A ±1	B	C ±5	D	E*	F	G	H	øL +1	J*	K	øL	M
Pi 21430	284	132	407	465	110	136	SW 30	G1 1/2	65	2	49	119	210
Pi 21430 FL	284	132	407	465	110	136	SW 30	-	-	-	49	119	210

Type	N	O	P	Q	R	S	T	U ±3	øV	W ±0,25	X ±0,25	Y
Pi 21430	62	31	136	167	28	M12x18	66	159	-	-	-	-
Pi 21430 FL	62	31	136	167	28	M12x18	66	159	38	69,9	35,7	M12x21

## 7. Installation, operating and maintenance instructions

### 7.1 Filter installation

When installing filter make sure that sufficient space is available to remove filter element and filter housing. Preferably the filter should be installed with the filter housing pointing downwards. The maintenance indicator must be visible.

### 7.2 Connecting the electrical maintenance indicator

The electrical indicator is connected via a 2-pole appliance plug according to DIN EN 175301-803 with poles marked 1 and 2. The electrical section can be inverted to change from normally open to normally closed position or vice versa. The state on delivery is a normally closed contact.

### 7.3 When should the filter element be replaced?

1. Filters equipped with visual and electrical maintenance indicator:  
During cold starts, the indicator may give a warning signal. Press the red button of the visual indicator once again only after operating temperature has been reached. If the red button immediately pops up again and/or the electrical signal has not switched off after reaching operating temperature the filter element must be replaced after the end of the shift.
2. Please always ensure that you have original Filtration Group spare elements in stock: Disposable elements (PS) cannot be cleaned.

### 7.4 Element replacement

**Note:** Elements may only be replaced by people who are familiar with the function of the filter. When replacing elements, appropriate safety clothing (protective goggles, gloves, safety shoes) must be worn.

**Note:** The maintenance indicator monitors the filter side in operation, which is identified by the position of the switching lever catch. The change-over transfer valve must be switched prior filter servicing. Now the signal of the maintenance indicators cancelled and the red button can be repressed again.

1. Operate and hold pressure equalizing lever located behind switching lever. Pull catch knob and swivel switching lever. Engage the catch on the clear filter side. Place through or drip pan underneath to collect leaving oil.
2. Loosen vent screw of the filter side not in use by 2-3 turns; max. until contact is made with the safety stop.
3. Unscrew filter housing by rotating same counter-clockwise and clean with a suitable medium.  
**Warning: The shift lever may not, from now until the screwing back in of the filter housing (7.), be activated under any circumstances!**
4. Remove filter element with a side-to-side motion.
5. Check O-ring on the filter house for damage. Replace, if necessary.
6. Make sure that the order number on the spare element corresponds to the order number of the filter name-plate.
7. Lightly lubricate the threads of the filter housing and screw into the filter head. Maximum tightening torque for NG 300 = 100 Nm.
8. To refill the filter chamber, operate only the pressure equalizing lever (leave the switching lever arrested in its catch) long enough for the medium to emerge bubble-free from the vent bore.
9. Tighten vent screw. Check filter for leaks by operating the pressure equalizing lever once again.
- 10.

## 8. Spare parts list

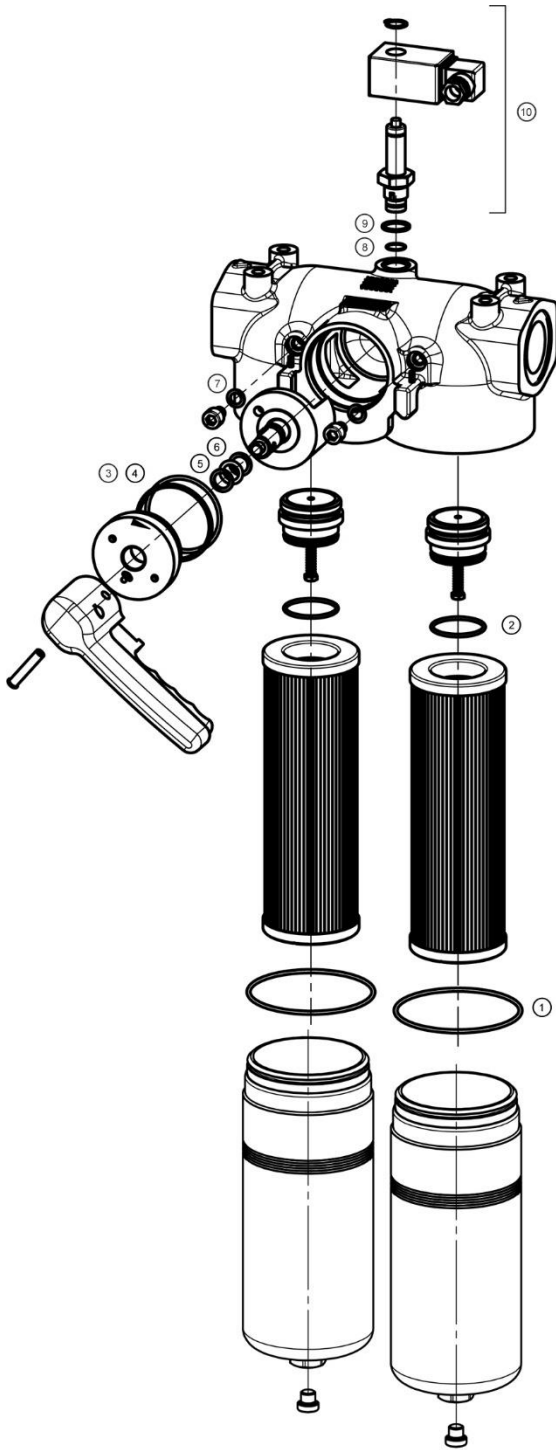

Order numbers for spare parts		
Position	Type	Order number
① - ⑦	Seal kit for housing	
	NBR	72464282
	FPM	72464283
	EPDM	72464284
⑧ - ⑨	Seal kit for maintenance indicator	
	NBR	77760309
	FPM	77760317
	EPDM	77760325
⑩	Maintenance indicator	
	Visual PiS 3098/2.2	77669971
	Electrical PiS 3097/2.2	77669948
	Electrical upper section only	77536550

### Your Contact

FILCOM GmbH  
Schönbuchstr. 1  
D-73760 Ostfildern

Phone: +49 (0) 711-4413322-0  
Fax: +49 (0) 711-4413322-22  
Mail: [info@filcom.de](mailto:info@filcom.de)

[www.filcom.de](http://www.filcom.de)

**FILCOM**<sup>®</sup>  
FILTRATION