

KAESER
COMPRESSORS®

Built for a lifetime.



Energy-Saving Refrigerated Dryers

Secotec™ TE, TF, and TG Series

370 to 3070 cfm

kaeser.com

Compact, energy-saving refrigerated dryers with impressive latent heat storage

Kaeser's renowned industrial-quality Secotec series refrigerated dryers have long been valued for their stable pressure dew point performance, exceptional reliability and low life-cycle costs. Now, the enhanced second generation offers even greater efficiency with a more compact design and further-optimized user-friendliness, thanks to such features as: the compact SECOPACK LS heat exchanger system with its high-efficiency latent heat storage, the standard-equipped, network-capable Sigma Control Smart controller and the innovative exhaust air control fitted to air-cooled refrigerated dryers from 1589 cfm. Furthermore, with the climate-friendly refrigerant R-513A, Kaeser assures security of supply for the future.

Energy cost savings

Thanks to its energy-saving control, surplus cooling performance can be stored temporarily in the thermal mass during partial load operation and subsequently used for drying, without the need for additional energy consumption. The rapid-reaction SECOPACK LS heat exchanger system ensures stable pressure dew points at all times.

Optimized and compact

The thermal mass storage in the highly efficient SECOPACK LS heat exchanger system is filled with a phase change material which, thanks to its significantly higher thermal storage density, requires 98% less storage material to achieve the same capacity as conventional storage media. This not only ensures excellent pressure dew point stability, but also drastically reduces the footprint of the unit. Optimized flow paths minimize pressure losses, thereby helping to enhance the efficiency of Secotec dryers.

Intuitive operation

The electronic Sigma Control Smart controller with color display and menu navigation is simple and intuitive to operate. Message memory, component-specific operating hour counters, and maintenance timers enable efficient monitoring and analysis of operational data. Floating contacts and a Modbus TCP communications module provide easy networking with master controllers, such as the Sigma Air Manager 4.0.

Long-term reliability

The high-performance refrigerant circuit in Secotec refrigerated dryers assures reliable performance in ambient temperatures up to 122°F. The large condensate separator and electronic Eco-Drain condensate drain provide reliable condensate removal during all load phases. Long service life is assured through the use of aluminum for the condenser and SECOPACK LS, while the compressed air piping is constructed from stainless steel. The innovative exhaust air control fitted to the Secotec TG reliably conveys away the exhaust heat, ensuring efficient and long-lasting operation.



Reduce life-cycle costs

Three factors are responsible for achieving the exceptionally low life-cycle costs associated with Secotec refrigerated dryers, namely: low-maintenance system design, energy-efficient components and, above all, the demand-dependent Secotec energy-saving control.

This triple combination enables a Secotec TF 340, for example, to achieve life-cycle cost savings of up to 50% when compared to other refrigerated dryers typically available on the market.

Conventional dryers

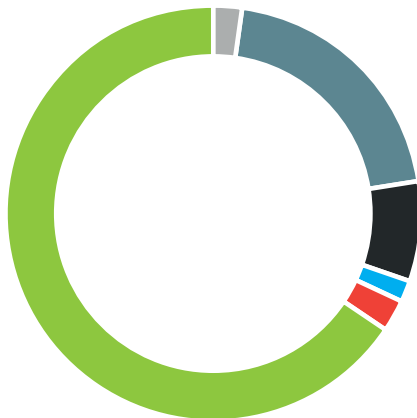

Secotec

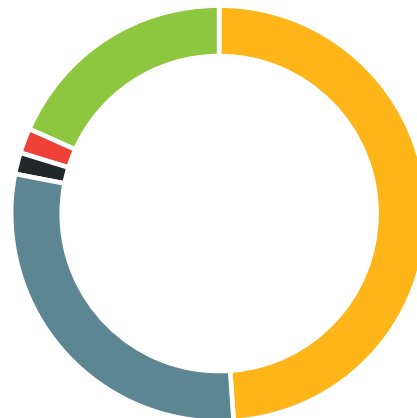

- Potential energy savings
- Prefilter investment
- Dryer investment
- Maintenance materials
- Prefilter energy costs (differential pressure)
- Refrigerated dryer energy costs (differential pressure)
- Electricity

Example: Secotec compared to conventional dryer

Secotec TE to TG series

Energy-efficient powerhouses

Consistent use of high-quality components and our decades of experience in system design allow Secotec refrigerated dryers to achieve exceptional energy efficiency – across the entire load range.



Efficient refrigerant compressor

The scroll refrigerant compressors used in Secotec dryers are up to 26% more efficient than reciprocating compressors. They therefore play an important role in ensuring the outstanding efficiency of Kaeser refrigerated dryers.



Minimal differential pressure

Second generation Secotec refrigerated dryers stand out for their remarkably low differential pressure. This is a result of the generously-dimensioned flow cross-sections within the heat exchanger and compressed air connection lines.



Efficient thermal mass

The efficient phase change material gives the exceptionally compact SECOPACK LS heat exchanger system its impressive thermal mass storage capacity. Special heat transfer elements ensure rapid charge and discharge, while premium-grade heat insulation boosts efficiency even further.



Significant energy savings

The Sigma Control Smart controller calculates the new Secotec dryer's load hours and current power consumption. This advanced system also displays the savings achieved as compared to conventional hot gas bypass refrigerated dryers.

Secotec TE to TG series

Reliable drying

We do not just talk about challenging operating conditions, but actually create them using our advanced climate testing facilities. This allows us to fine-tune the design of Secotec refrigerated dryers in order to ensure maximum reliability at all times.



Smart controller

The innovative Sigma Control Smart controller regulates the operation of the thermal mass while constantly monitoring system temperature and pressure values. Automatic wire break and short circuit monitoring add even greater operational security.

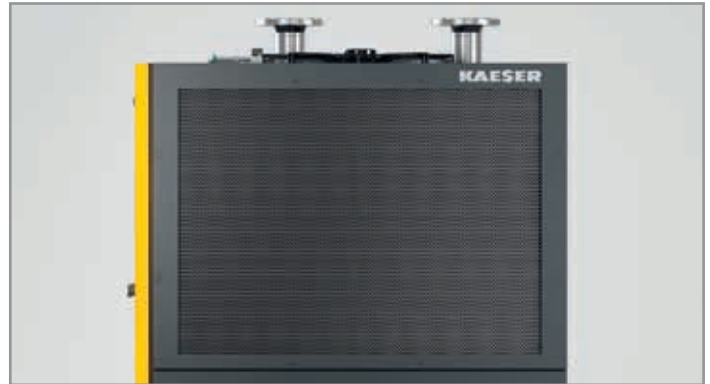

Compact condenser

Aluminum micro-channel condensers with large surfaces ensure effective contamination reserve, while their compact design saves both space and refrigerant quantities. This enables Secotec refrigerated dryers to deliver reliable drying performance even at high ambient temperatures.



Reliable separation

The SECOPACK LS heat exchanger system is made of corrosion-resistant aluminum and includes an integrated, large-diameter condensate separator for reliable separation of condensate during all load phases.



Future-proof refrigerant

The refrigerant circuit in Secotec refrigerated dryers is specifically designed for the use of R-513A refrigerant. This ensures maximum efficiency and reliability, even at the highest temperatures, while providing the best solution currently available for the security of your future supplies.

Secotec TE to TG series

Easy installation and excellent accessibility

Kaeser understands our customers' needs very well, as the company itself operates numerous compressed air stations. From first-hand experience, we are well-versed in all aspects of compressed air station planning, commissioning, operation, and maintenance. We draw on this expertise to create user-friendly products with minimal need for maintenance.



Left-hand side compressed air connections (optional)

If required, Secotec TF refrigerated dryers are available with compressed air connections located at the top of one side. This customized solution enables rapid installation at low cost.



Externally accessible: Eco-Drain

The standard-equipped Eco-Drain electronic condensate drain is conveniently located on the exterior of the unit, where it is easily accessible for functional testing. The service unit can be replaced without depressurization of the refrigerated dryer by simply closing the condensate inlet valve beforehand.

Secotec — The ultimate space-saver

TE and TF series...



...with two wall sides

Secotec TE and TF series units can be installed against walls on two sides, leading to even further space savings.

TE and TF series...



...the compact duo

Where multiple energy-saving refrigerated dryers are required, Secotec TE and TF series units can easily be installed together as a compact duo.



Quick maintenance access

On Secotec TE and TF series units, removable panels allow easy access to all maintenance components. On TG series units, maintenance access is provided via large doors. The micro-channel condenser is also easily accessed for cleaning.

TE, TF, and TG series...



...back-to-back

Two energy-saving refrigerated dryers and not much space? No problem! TE, TF and TG series refrigerated dryers are equipped for back-to-back installation.

TG series...



...with just one wall side

The Secotec TG series combines maximum performance with a minimum need for space. Even installation against the wall on just one side poses no problem.

Sigma Control Smart

Comprehensive information and intuitive operation

The electronic Sigma Control Smart controller with color display and menu navigation is simple and intuitive to operate. Message memory, component-specific operating hour counters and maintenance timers enable efficient monitoring and analysis of operational data. Floating contacts and a Modbus TCP communications module provide easy networking with master controllers, such as the Sigma Air Manager 4.0.

Operational status can be viewed at a glance via the dew point trend indicator, prominent display of active messages and current operating data, as well as a clearly arranged P&I diagram. A message memory and floating message contacts, together with the standard-equipped network interface, provide highly effective analysis and monitoring capability. All information can be communicated to a master controller via the Sigma Network.



Main menu

- Pressure dew point trend display
- Eco-symbol displayed when thermal mass activated
- List of additional menus, symbols: Controls for voltage, fault, warning/maintenance, remote on/off, controller on
- Status indicator for component-specific messages
- Flagging of pending maintenance/warning and affected component
- Faults requiring action indicated in red



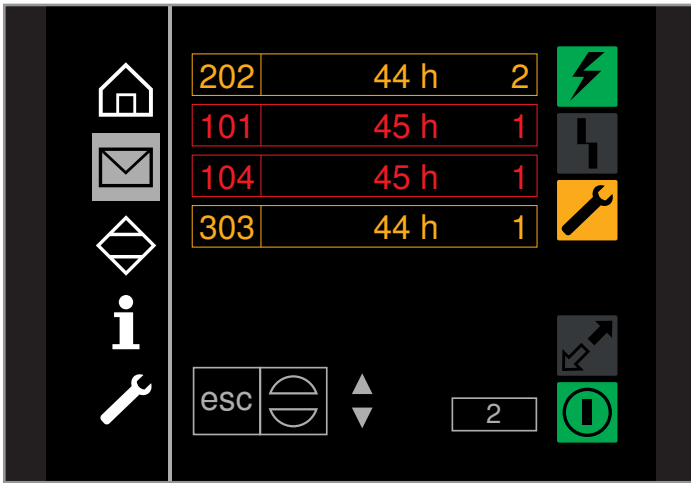

Messages

- Maintenance/warning: indicated in orange
- Faults: indicated in red
- Unacknowledged message: indicated by a border
- Messages identifiable by numerical codes
- Messages time stamped with operating hours
- Counter shows number of past messages

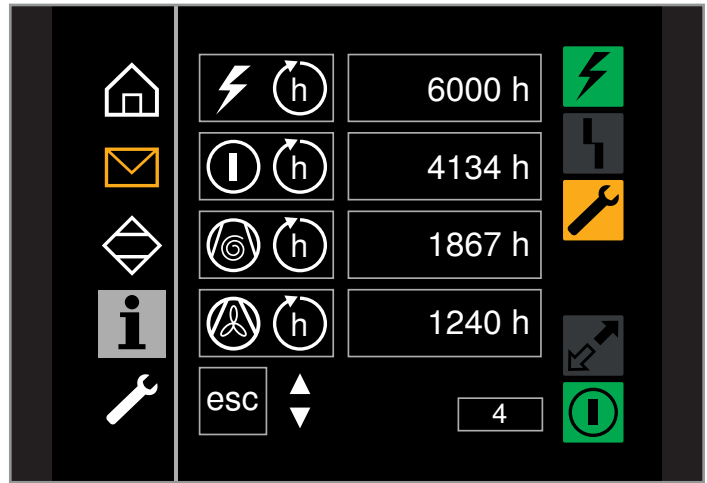

Information

- Multiple operating hour counters
- Temperature thresholds for messages
- Activation of remote on/off
- Display of actual electrical power consumption- Estimated energy savings compared to dryers with hot gas bypass control
- Change measurement units

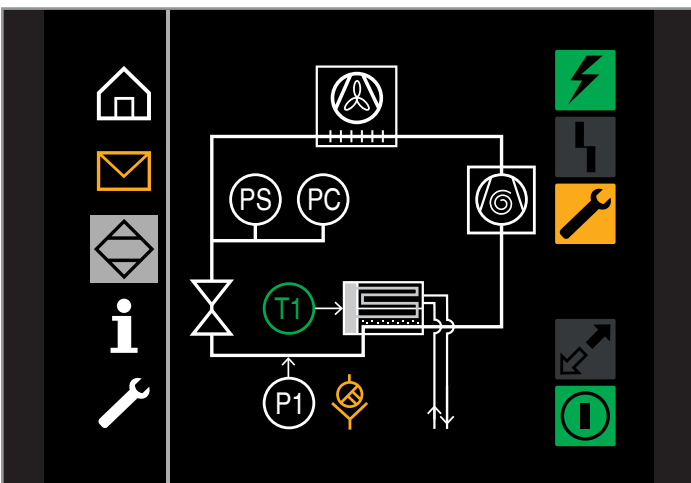

P&I diagram

- Displays functional principle
- Messages displayed with colored switch symbols (e.g. condensate drain maintenance)

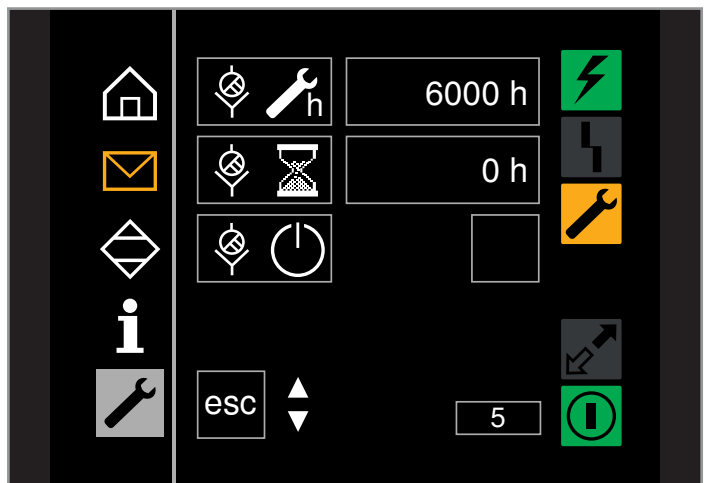

Service

- List of individual maintenance intervals for condensate drain and condenser cleaning
- Current interval status
- Reset maintenance timer

Innovative energy-saving control with Storage Plus

For its Storage Plus energy-saving control, KAESER uses a special phase change material that absorbs latent heat. In contrast to other thermal mass storage systems available on the market, the heat energy does not go through a temperature change; rather, it goes through a phase change. Only when the

entire medium has undergone this phase change - meaning that the storage is now full - does the temperature begin to rise. When the latent heat is discharged, the phase change reoccurs in the opposite direction, with the temperature remaining constant until all the heat has been discharged.

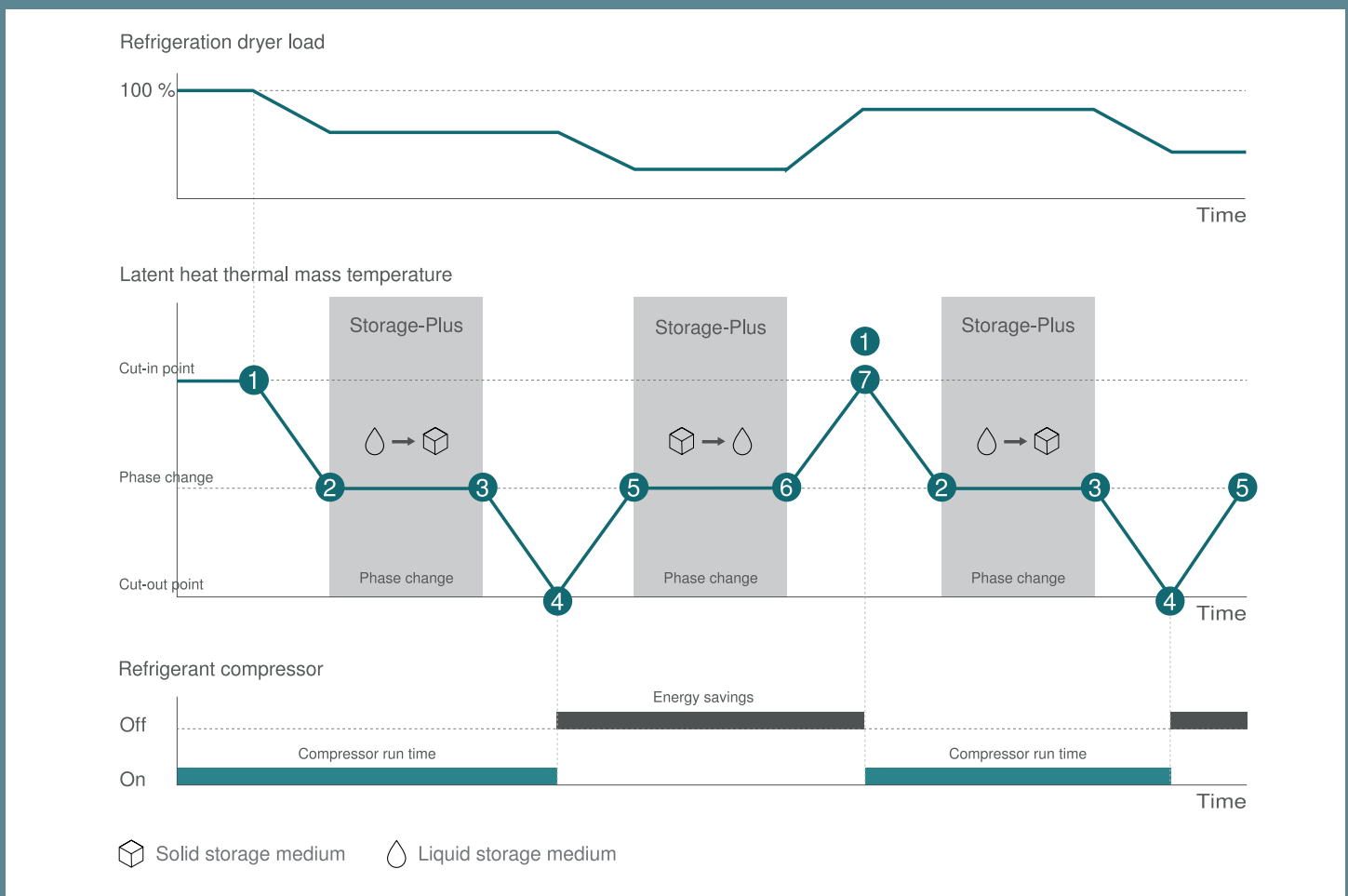

- (1) Refrigerant compressor runs: Cooling is supplied for drying the compressed air and cooling down the thermal mass.
- (2) Thermal mass solidifies at constant temperature and transfers a significant amount of heat to the refrigerant.
- (3) Refrigerant cools the thermal mass down further until the cut-out temperature is reached.
- (4) Refrigerant compressor switches off.
- (5) Thermal mass provides cooling for drying the compressed air and, in doing so, warms up.
- (6) Thermal mass melts at constant temperature, taking on a significant amount of heat from the moist compressed air.
- (7) Thermal mass warms up to the cut-in temperature of the refrigerant compressor.

Modbus TCP communications module

Secotec - Industrie 4.0 ready

With their standard-equipped Modbus TCP module, Secotec refrigerated dryers can be connected to the Sigma Air Manager (SAM) 4.0 and the SIGMA NETWORK. All essential operational parameters and messages are available in real-time, enabling comprehensive monitoring of the entire compressed air station and creating the basis for preventative maintenance based on need. The result: maximum air availability for minimal cost.

Furthermore, the SAM 4.0 provides a complete overview of all of the refrigerated dryer's essential operating parameters. Color-coded warnings and alarms are displayed in the compressed air station's P&I diagram. By selecting the dryer icon, all key operational parameters and message texts are displayed in plain text.



Sigma Air Manager 4.0

D1 - TE 102

Model: TE 102

Electrical power consumption: 0.87 kW
Pressure dew point: **Normal**
Warning limit, yellow range: 14.0 °C
Warning limit, red range: 20.0 °C

Automatic restart: Yes
Remote control: No

Operating hours: 10598 h
Remaining maintenance hours, Condensate drain: 1374 h
Remaining maintenance hours, Condenser cleaning: -17 h
Group warning: No
Group alarm: No

"Condenser cleaning" maintenance due

Close



SIGMA CONTROL SMART

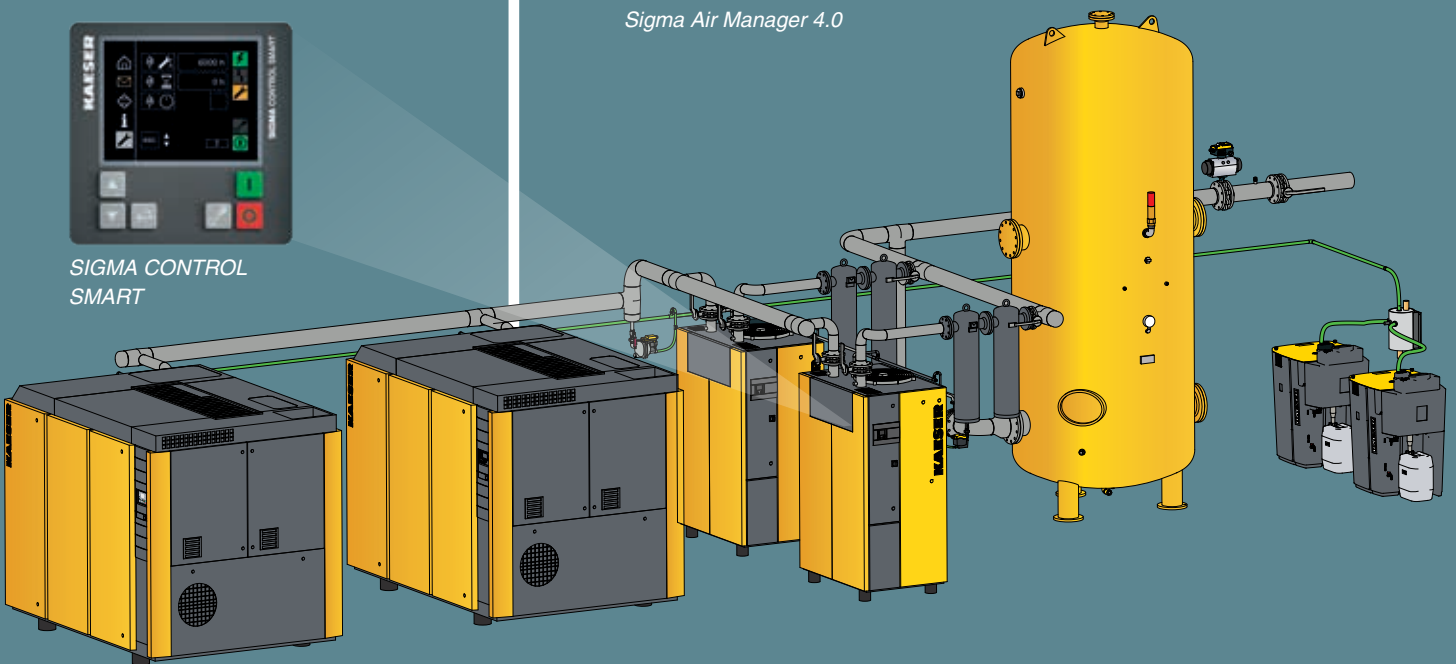

SECOPACK LS heat exchanger system

The high-efficiency module for maximum energy savings

Second generation Secotec refrigerated dryers are equipped with the innovative SECOPACK LS heat exchanger system. Its latent heat thermal mass is composed of a phase change material. Compressed air warms the material up to its melting point (thermal mass discharge), absorbing heat during the process. This is significantly more than the amount of heat that it can absorb based on its normal specific heat capacity (without the phase change properties), so the latent heat thermal mass in Secotec dryers has a dramatically higher thermal density than equivalent conventional systems and is therefore capable of delivering the same performance using 98% less thermal mass material.

The result: High thermal mass storage capacity for stable pressure dew points and long-life operation, combined with a dramatically reduced unit footprint.



Image: SECOPACK LS in Secotec TF

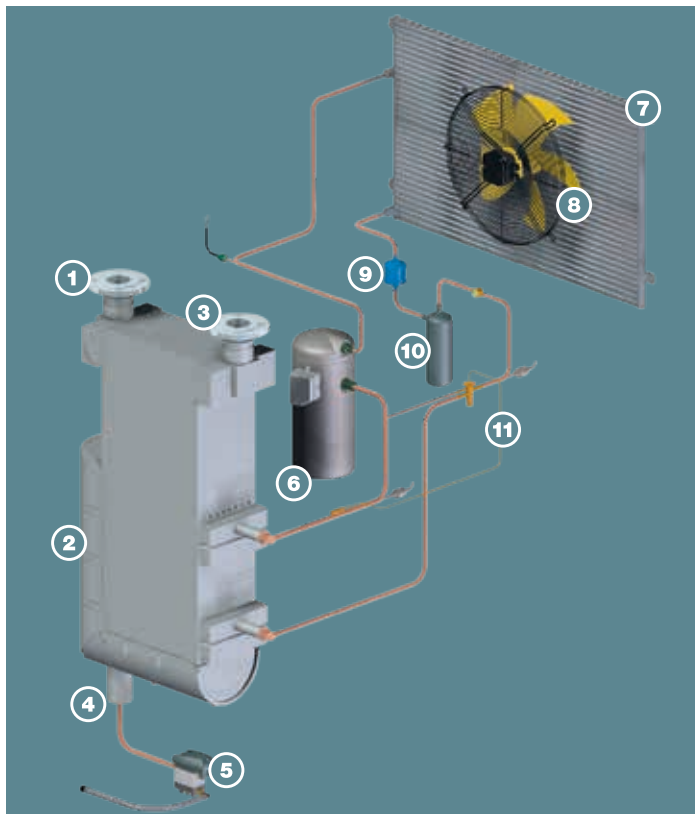

Schematic

- (1) Compressed air inlet
- (2) SECOPACK LS heat exchanger system
- (3) Compressed air outlet
- (4) Condensate separator
- (5) Eco-Drain condensate drain
- (6) Micro-channel condenser
- (7) Refrigerant compressor
- (8) Fan
- (9) Filter dryer
- (10) Refrigerant collector
- (11) Expansion valve

SECOPACK LS

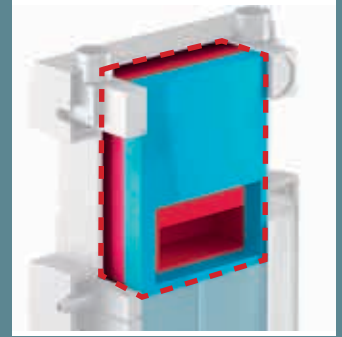
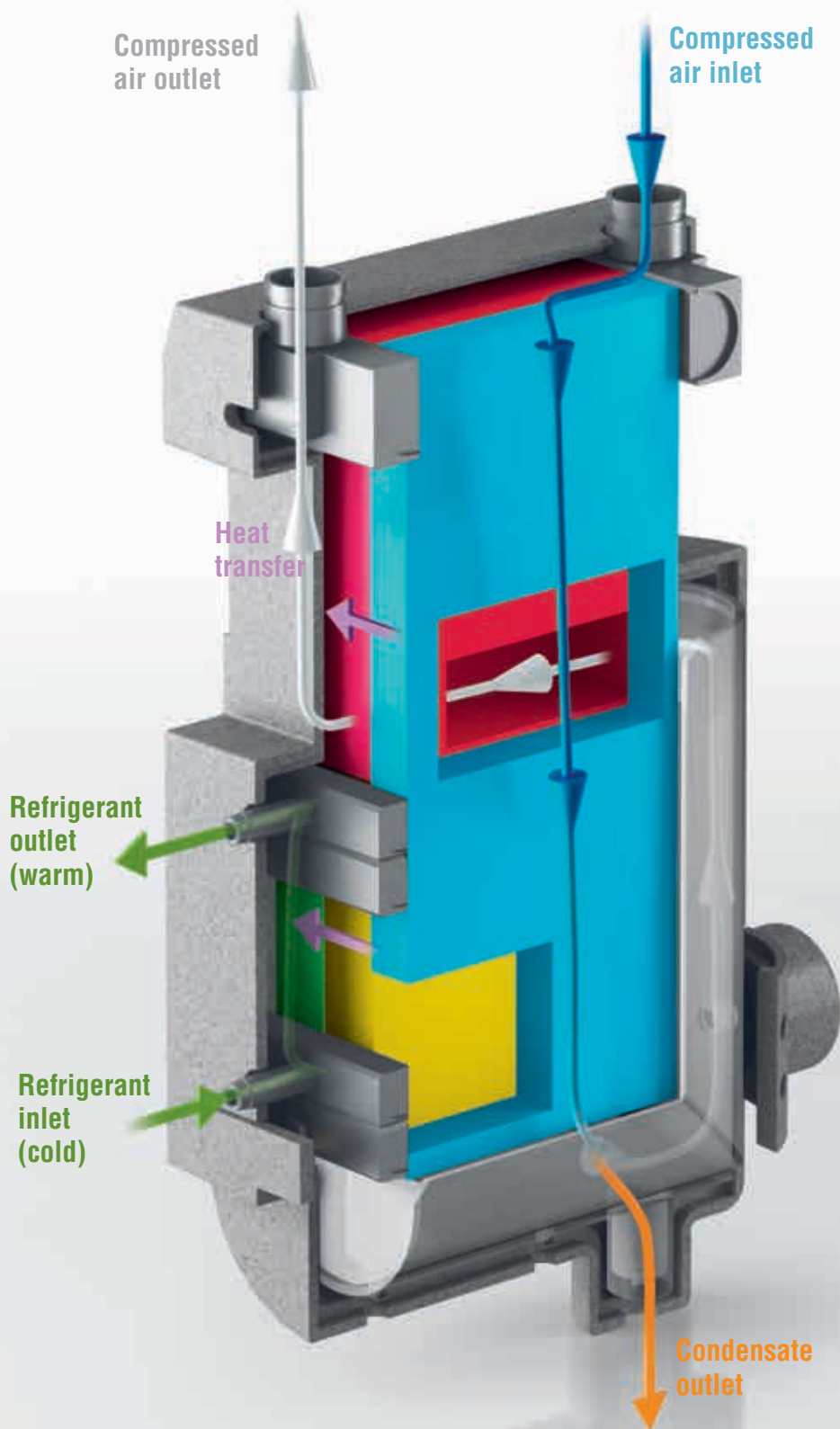

Air/air heat exchanger

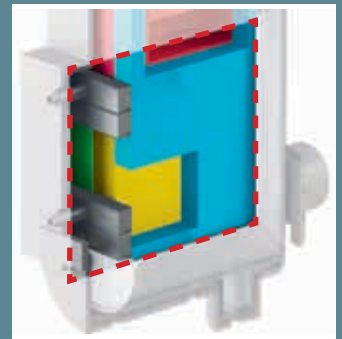

Air/refrigerant heat exchanger

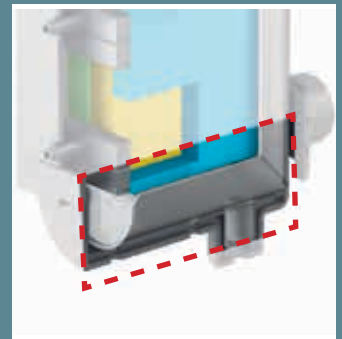

Condensate Separator

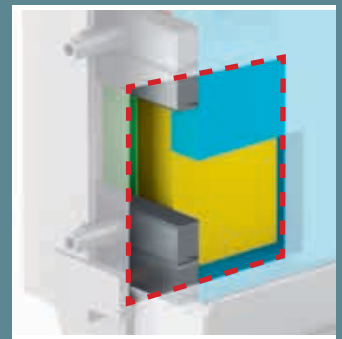

Thermal mass (yellow section)

Secotec TG series

Secotec TG

Secotec TG series energy-saving refrigerated dryers can accommodate flow rates up to 3461 cfm and are available with a choice of air or water-cooling. Designed for large-scale industry, these compact giants ensure stable pressure dew point performance even under the toughest of operating conditions - with maximum reliability and minimal life-cycle costs.

The high-performance thermal mass concept and standard, network-capable Sigma Control Smart controller guarantee long-lasting, energy-saving operation in all load phases. The innovative exhaust air control, fitted on air-cooled variants, sets new standards for operational safety and cost efficiency.



Innovative exhaust air control

Dependent on load, the frequency-controlled radial fan draws off the accumulating exhaust heat from the refrigerated dryer via the cooling air flow. Thanks to a residual thrust of 0.60 inches of water and autonomous control, direct connection to standard exhaust and collector ducting is possible.



Thermal mass concept with multiple compressors

The SECOPACK LS heat exchanger system with latent heat thermal mass operates in combination with up to three refrigerant compressors arranged in parallel. These are switched continuously according to the load level, thereby relieving the load on the thermal mass, allowing it to be made even more compact.

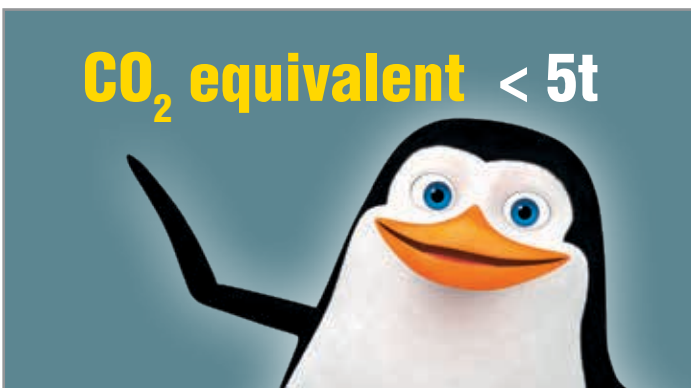

Reduced operator responsibilities

Due to its compact components, the Secotec TG operates using particularly low levels of refrigerant charge. Low greenhouse gas potential also ensures cost-effective compliance with national operator regulations. It is still recommended to have the unit inspected once per year by an authorized Kaeser service representative.



Minimal service costs

The condensate separator in the SECOPACK LS does not require servicing. It is just a matter of replacing the service unit in the standard Eco-Drain condensate drain - no further maintenance work is required. Unlike typical axial fans, the radial fans in the Secotec TG are designed to last for the unit's entire service life.

Your **benefits** compared to previous models, at a glance

No risk of thermal overload

Refrigerated dryers are usually supplied without a dedicated exhaust air duct. The result is thermal overload - caused by hot exhaust air being drawn back in as cooling air. However, the innovative exhaust air control on the Secotec TG, coupled with its direct connection to the exhaust air duct, reliably prevents this issue from occurring.

No unwanted air intake, no auxiliary fan

In the case of conventional ventilation systems, which use air hoods and auxiliary fans, air from the room is invariably drawn in. This is not so with the Secotec TG: the exhaust air flow is minimized, which means smaller ducting can be used and the auxiliary fan becomes redundant.

Innovative exhaust air control

Its innovative exhaust air control allows the Secotec TG to be connected directly to the compressor station; the resulting significant space-savings reduce planning and installation costs. Optimal cooling also serves to ensure stable pressure dew points and long-lasting, energy-saving operation.

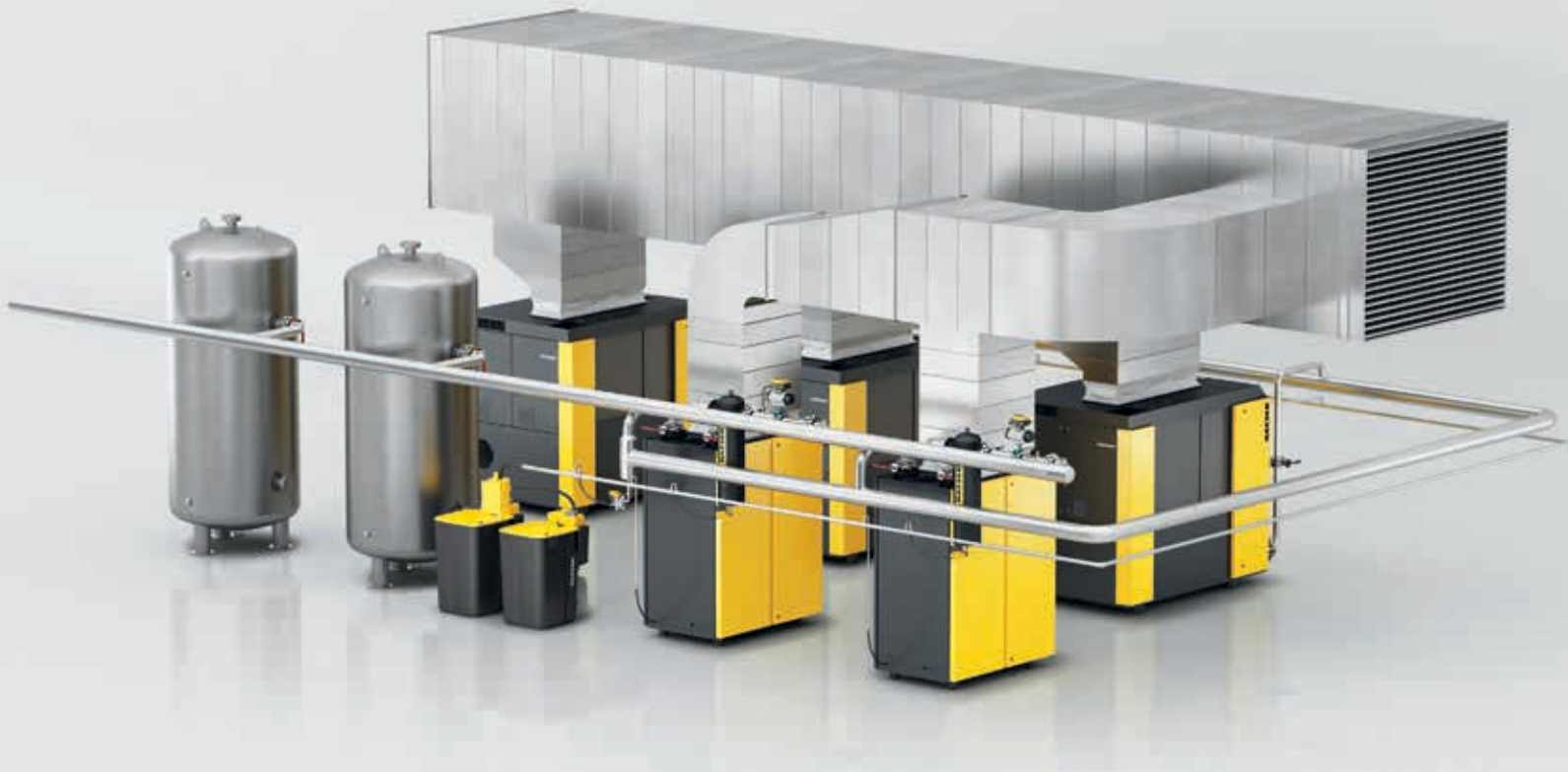
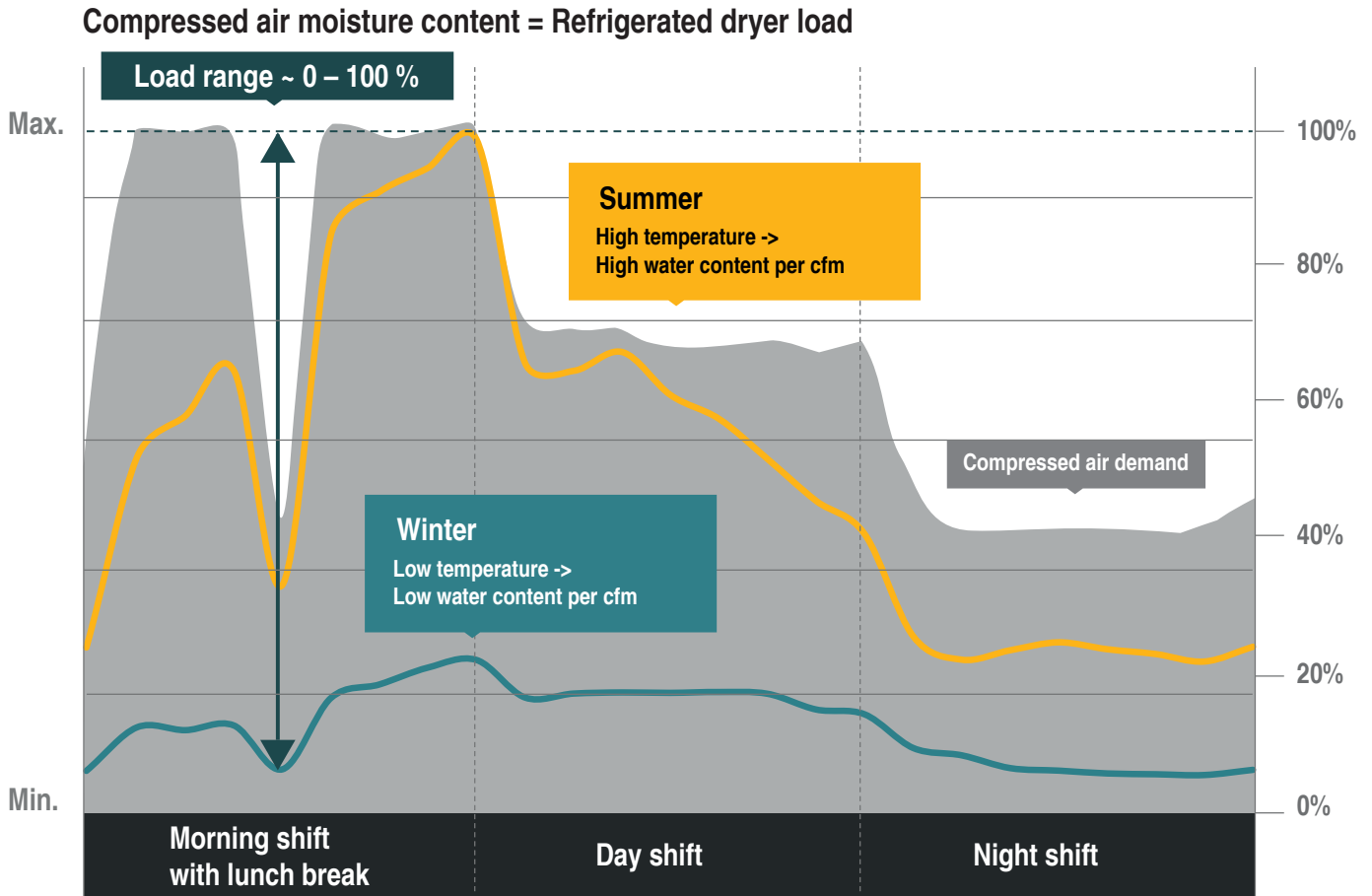

Image: Example air station with collector duct for compressors and refrigerated dryer

The key to perfect refrigerated drying



Secotec – Savings for all seasons

The load on a refrigerated dryer depends not only on the volume of compressed air to be dried (gray area), but more importantly, on how much water the incoming compressed air contains. This volume of water (moisture) increases as the temperature rises, so the load on refrigerated dryers increases dramatically when ambient temperatures are high, such as during the summer (yellow curve).

Lower temperatures during the winter (teal blue curve) therefore reduce the load on refrigerated dryers accordingly. To maintain a stable pressure dew point throughout all these fluctuations, refrigerated dryers should always be designed to provide sufficient performance during peak load times, and should also have additional reserve capacity.

Aside from these fluctuations in air flow and temperature, the output of refrigerated dryers constantly varies between 0 and 100% of capacity. Because the Secotec thermal mass control ensures energy is only used as needed across this entire load range, users benefit from exceptional savings.

Maximum energy savings due to thermal mass control

Refrigerated dryer load constantly fluctuates between 0 and 100%. Unlike conventional partial load control systems, Secotec thermal mass control precisely adjusts electrical power consumption during all load phases.

This allows Secotec refrigerated dryers to save almost 60% of energy costs compared to refrigerated dryers with hot gas bypass control running at an average of 40% of capacity. In contrast to conventional systems, the thermal mass in Secotec dryers always remains cool.

This means compressed air can be dried effectively even during start-up phases. The high-quality insulation around the thermal mass also helps keep energy

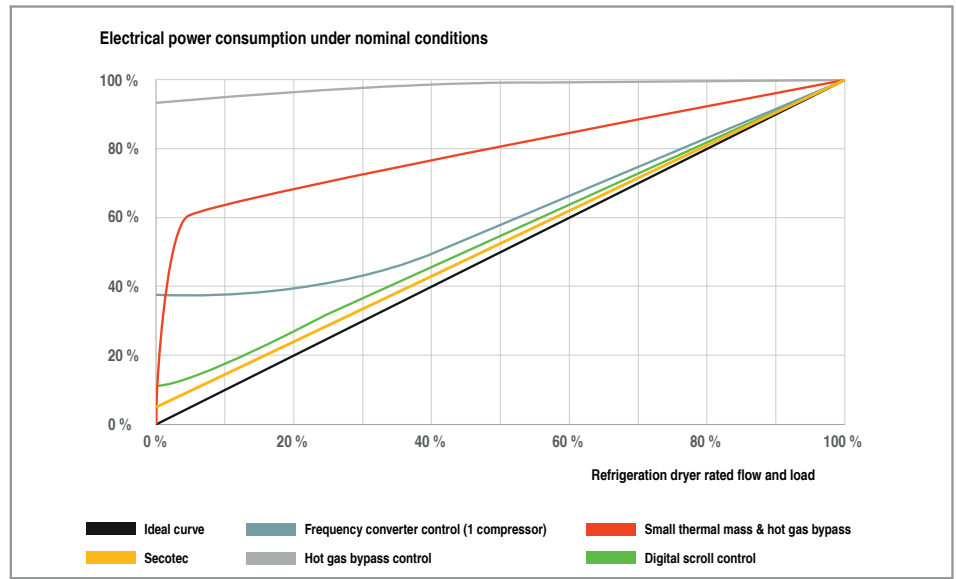

usage to a minimum. Compressed air drying with Secotec refrigerated dryers not only ensures exceptional energy efficiency, but also, thanks to their

impressive thermal capacity, provides low-wear operation.

Optimal drying with low-wear operation

Secotec refrigerated dryers efficiently maintain pressure dew points down to 45°F during full load operation. Thanks to their narrow fluctuation range, pressure dew points are also more stable during partial load operation than is the case with conventional refrigerated dryers.

Conventional refrigerated dryers with switching operating modes, but without an additional thermal mass, use the heat exchanger material itself as a thermal mass. In these dryers it is therefore necessary to switch the refrigerant compressors and fan motors on and off much more frequently, in order to maintain the required cooling performance.

To reduce switching frequency and wear, the refrigerant circuit therefore only switches on at much higher pressure dew points. The resulting fluctuations in the pressure dew point negatively affect

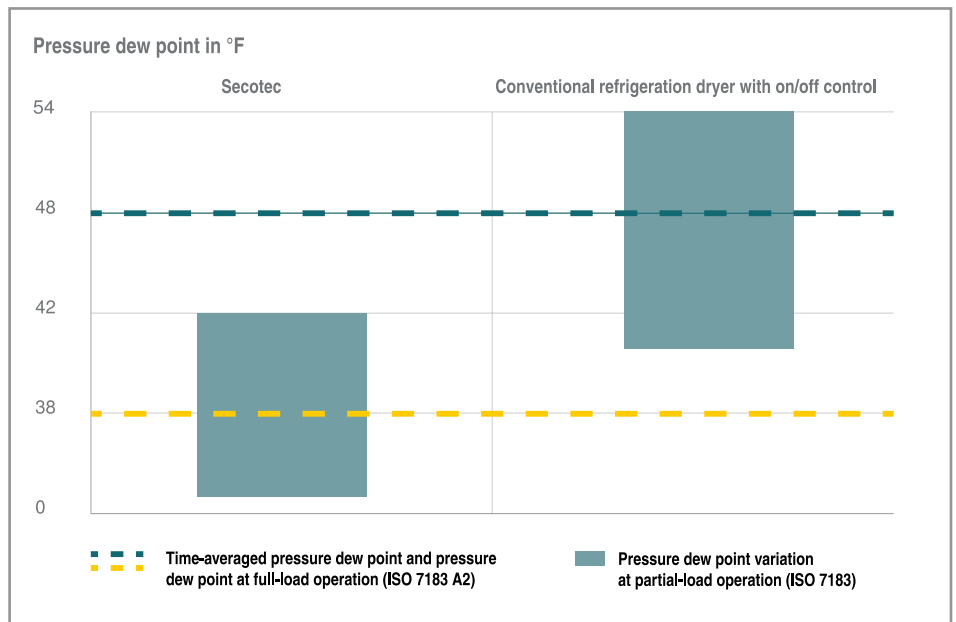

drying performance. This can be risky, since corrosion can take hold even with relative compressed air humidity of 40% – corrosion can therefore occur even without condensate formation. Secotec refrigerated dryers, on the other hand, ensure long-life operation thanks to their

high thermal mass storage capacity. Once the thermal mass has been charged, the refrigerant compressor and fan motor can remain switched off for much longer without impacting on pressure dew point stability.

Secotec TE to TG series

Technical specifications

Model	Rated Capacity (1) (scfm)	Power Supply (V / Ph / Hz)	Air Cooled Power Consumption (kW) According to ISO 7183 Opt A2	Inlet / Outlet Connections (in.)	Dimensions W x D x H (in.)	Weight (lb.)	Maximum Working Pressure (psig)
TE 102	370	208 / 3 / 60	1.6	2 NPT	28 x 41 x 65	505	232
TE 122	410		1.9			507	
TE 142	490		2.3			549	
TF 174 (2)	550	230 / 3 / 60	2.5	2-1/2 FLG	33 x 49 x 79	765	
TF 230 (2)	740	460 / 3 / 60	3.3	3 FLG		830	
TF 280 (2)	900	575 / 3 / 60	3.9			865	
TF 340 (2)	1130	4.5	925				
TG 450 (2)	1340	460 / 3 / 60	5.1	4 FLG	41 x 66 x 84	1405	188
TG 520 (2)	1550		6.0			1450	
TG 650 (2)	1910		7.2	6 FLG		1555	
TG 780 (2)	2330		9.0			1545	
TG 980 (2)	3070		14.9			1685	

(1) Rated capacity: Based on compressed air saturated at 100°F and 100 psig and operation in a 100°F ambient.

(2) Available water-cooled, rated capacity will increase, consult factory.

- Maximum inlet temperature: 140°F

- Minimum/maximum ambient air temperature:

Air-cooled dryers:

38°F / 110°F (TE and TF)

38°F / 120°F (TG)

Water-cooled dryers:

38°F / 120°F

- High ambient temperature option is available for air-cooled TE and TF, extending max ambient temperature to 120°F

Specifications are subject to change without notice.

Selecting the Proper Dryer

To correct Rated Capacity for actual operating conditions, refer to “Capacity Correction Factors for Operating Conditions” and “Capacity Correction Factors for Ambient Temperature”. Find the capacity correction factors corresponding to the inlet and ambient conditions. Multiply these factors to find the “overall” capacity correction factor, then multiply any dryer’s rated capacity by the overall correction factor to determine its capacity at your operating conditions. Capacity correction factors for conditions not shown may be interpolated.

Capacity Correction Factors for Operating Conditions

Inlet Pressure (psig)	Inlet Temperature (°F)											
	75	80	85	90	95	100	105	110	115	120	125	130
60		0.96			0.86	0.77	0.67	0.60	0.53	0.47	0.41	0.37
80		1.11			0.99	0.89	0.78	0.69	0.61	0.54	0.48	0.42
100		1.25			1.12	1.00	0.88	0.78	0.69	0.61	0.53	0.48
115		1.32			1.18	1.05	0.93	0.82	0.73	0.64	0.57	0.50
120		1.33			1.19	1.06	0.94	0.83	0.73	0.65	0.57	0.51
125		1.35			1.21	1.08	0.95	0.84	0.75	0.66	0.58	0.52
140		1.39			1.25	1.11	0.98	0.87	0.77	0.68	0.60	0.53
160		1.46			1.31	1.16	1.02	0.91	0.80	0.71	0.63	0.56
180		1.51			1.35	1.21	1.06	0.94	0.83	0.73	0.65	0.58
200		1.55			1.39	1.24	1.09	0.97	0.85	0.75	0.67	0.59
230		1.59			1.43	1.27	1.12	0.99	0.88	0.77	0.68	0.61

Capacity Correction Factors for Ambient Temperature

Factor	Ambient Air Temperature (°F)									
	75	80	85	90	95	100	105	110	115	120
		1.09			1.05	1.00	0.96	0.92	0.87	0.81

TE Series



TF Series



TG Series



The world is our home

As one of the world's largest compressed air systems providers and compressor manufacturers, Kaeser Compressors is represented throughout the world by a comprehensive network of branches, subsidiary companies and factory trained partners.

With innovative products and services, Kaeser Compressors' experienced consultants and engineers help customers to enhance their competitive edge by working in close partnership to develop progressive system concepts that continuously push the boundaries of performance and compressed air efficiency. Every Kaeser customer benefits from the decades of knowledge and experience gained from hundreds of thousands of installations worldwide and over ten thousand formal compressed air system audits.

These advantages, coupled with Kaeser's worldwide service organization, ensure that our compressed air products and systems deliver superior performance with maximum uptime.



**KAESER
COMPRESSORS** ®

Built for a lifetime.

www.kaeser.com

Kaeser Compressors, Inc.
511 Sigma Drive
Fredericksburg, VA 22408 USA
Telephone: 540-898-5500
Toll Free: 800-777-7873
info.usa@kaeser.com

Kaeser Compressors Canada Inc.
3760 La Vérendrye Street
Boisbriand, QC J7H 1R5 CANADA
Telephone: (450) 971-1414
Toll free: (800) 477-1416
info.canada@kaeser.com

Kaeser Compresores de México S de RL de CV
Calle 2 #123
Parque Industrial Juríca
76100 Querétaro, Qro.
Telephone: 01 (442) 218 64 48
sales.mexico@kaeser.com

Kaeser Compresores de Guatemala y Cia. Ltda.
Calz. Atanasio Tzul 21-00, zona 12
El Cortijo II, Bodega 501
01012-Guatemala City
Telephone: +502 2412-6000
info.guatemala@kaeser.com

